

# User Manual

# KNV



KNV  
CUBE



KNV  
ARC

Software Version 14



GLP® KNV Cube and Arc User Manual – Revision A

This manual covers fixture software version 14

---

© 2018 German Light Products GmbH. All rights reserved.

The marks 'GLP' and 'German Light Products' are trademarks registered as the property of German Light Products GmbH in Germany, in the United States of America and in other countries.

The information contained in this document is subject to change without notice. German Light Products GmbH and all affiliated companies disclaim liability for any injury, damage, direct or indirect loss, consequential or economic loss or any other loss occasioned by the use of, inability to use or reliance on the information contained in this document.

Manufacturer's head office:

German Light Products GmbH (GLP), Industriestrasse 2, 76307 Karlsbad, Germany  
Tel (Germany): +49 7248 92719 - 0

Service & Support EMEA:

GLP, Industriestrasse 2, 76307 Karlsbad, Germany  
Tel. (Germany): +49 7248 9271955

Email: [support@glp.de](mailto:support@glp.de)

[www.glp.de](http://www.glp.de)

Service & Support USA:

GLP USA, 1145 Arroyo St., Ste. A, 91340 San Fernando, California  
Tel (USA): +1 818 767 8899

Support (US): [info@germanlightproducts.com](mailto:info@germanlightproducts.com)

[www.germanlightproducts.com](http://www.germanlightproducts.com)

## Table of Contents

1.	Safety .....	4
	Key to symbols.....	4
	GLP Service and Support.....	5
2.	KNV Cube overview .....	6
3.	KNV Arc overview .....	7
4.	Features .....	8
	White LEDs .....	8
	Color LEDs.....	8
	Pixel mapping.....	9
	Pixel mirror .....	9
	Pixel orientation.....	10
	Dimming .....	10
	Flare effect.....	10
	Hyperspeed .....	10
	FX .....	10
	RGB color generator .....	13
	Extra shutter .....	13
	Behavior when the fixture is not receiving a DMX signal.....	13
	Dimmer Flash mode.....	13
	Display .....	14
	Fan modes .....	14
	Fixture information .....	15
	Test pattern .....	15
	Custom settings and factory defaults .....	15
5.	Control menus and LCD display .....	17
6.	Fixture control setup .....	18
7.	Control menu layout.....	19
8.	DMX control modes .....	22
	Special notes on the DMX tables .....	23
	Control channel layout.....	24
	DMX Mode 1: RGBW 16-bit.....	24
	DMX Mode 2: White strobe with FX, RGB with FX.....	26
	DMX Mode 3: RGB strobe with FX, White 25-pixel.....	32
	DMX Mode 4: White strobe with FX, RGB 25-pixel.....	37
	DMX Mode 5: Multi-layer RGBW with FX.....	42
	DMX Mode 6: RGBW 25-pixel, 8-bit .....	49
	DMX Mode 7: RGBW 25-pixel, 16-bit .....	52

## 1. Safety

### Key to symbols

The following symbols are used in the product's user documentation:



**Warning!** Safety hazard.  
Risk of injury or death.



**Warning!** Hazardous voltage.  
Risk of lethal or severe  
electric shock.



**Warning!** See user  
documentation for  
important safety  
information.



**Warning!** Fire hazard.



**Warning!** Risk of eye  
injury.



**Warning!** Read the **KNV Quick Start and Safety Manual** supplied with the product and available for download from [www.glp.de](http://www.glp.de) before installing, using or servicing the product. The **Quick Start and Safety Manual** contains important information for the safe use of KNV fixtures. If you fail to read that information you may create a safety hazard with a risk of injury, death or damage.

If you have any doubts or questions about how to use the product safely, contact your GLP supplier for assistance. Your GLP supplier will be happy to help.

The user documentation for GLP® KNV lighting fixtures consists of three documents:

- The **KNV Quick Start and Safety Manual**, supplied with KNV fixtures and available for download from [www.glp.de](http://www.glp.de). The Quick Start and Safety Manual contains important safety information and installation instructions that the installer and user must read. It also contains dimensions drawings and technical specifications for the product.
- The **KNV User Manual**, available for download from [www.glp.de](http://www.glp.de). The User Manual explains features and control of KNV fixtures.
- The **KNV DMX Channel Index**, available for download from [www.glp.de](http://www.glp.de). The Channel Index is a separate document containing the DMX control channel layout and DMX commands available in the fixture. This information is also available in the product's user manual.

The KNV is intended for use by experienced professionals with the knowledge and skills to set up, operate, and maintain high-powered, remotely controlled lighting equipment safely and efficiently. These operations require expertise that may not be provided in this manual.

- Respect all warnings and directions given in the product's user documentation and on the product. Read the product's Quick Start and Safety Manual and familiarize yourself with the safety precautions it contains before installing, using or servicing the product. GLP and affiliated companies will take no responsibility for damage or injury resulting from disregard for the information in the user documentation.
- Check the GLP website at [www.glp.de](http://www.glp.de) and make sure that you have the latest versions of the product's Quick Start and Safety Manual and this user manual.
- Check the fixture software version indicated on page 2 of this user manual and then use the fixture's control panel to check the version installed in the fixture. If the versions are not the same, the user manual may still cover the fixture, because software updates do not always affect the way you use the fixture. However, it is possible that the manual does not match the fixture perfectly. Software release notes can help clarify this question. You can consult software release notes and download the correct version of this user manual on the GLP website if necessary.
- Make both the Quick Start and Safety Manual and this user manual available to all persons who will install, operate or service the product. Save both documents for future reference.
- If you have any questions about the safe operation of the fixture, please contact an authorized GLP distributor (see list of distributors at [www.glp.de](http://www.glp.de)).

### ***GLP Service and Support***

Contact information for the nearest GLP Service and Support is available online at [www.glp.de/en/service](http://www.glp.de/en/service), by email at [info@glp.de](mailto:info@glp.de), or by telephone at the following numbers:

- GLP Germany: +49 (7248) 927 19-55
- GLP N. America: +1 818 767-8899
- GLP UK: +44 1392 690140
- GLP Asia: +852 (3151) 7730
- GLP Nordic: +46 737 57 11 40

## 2. KNV Cube overview

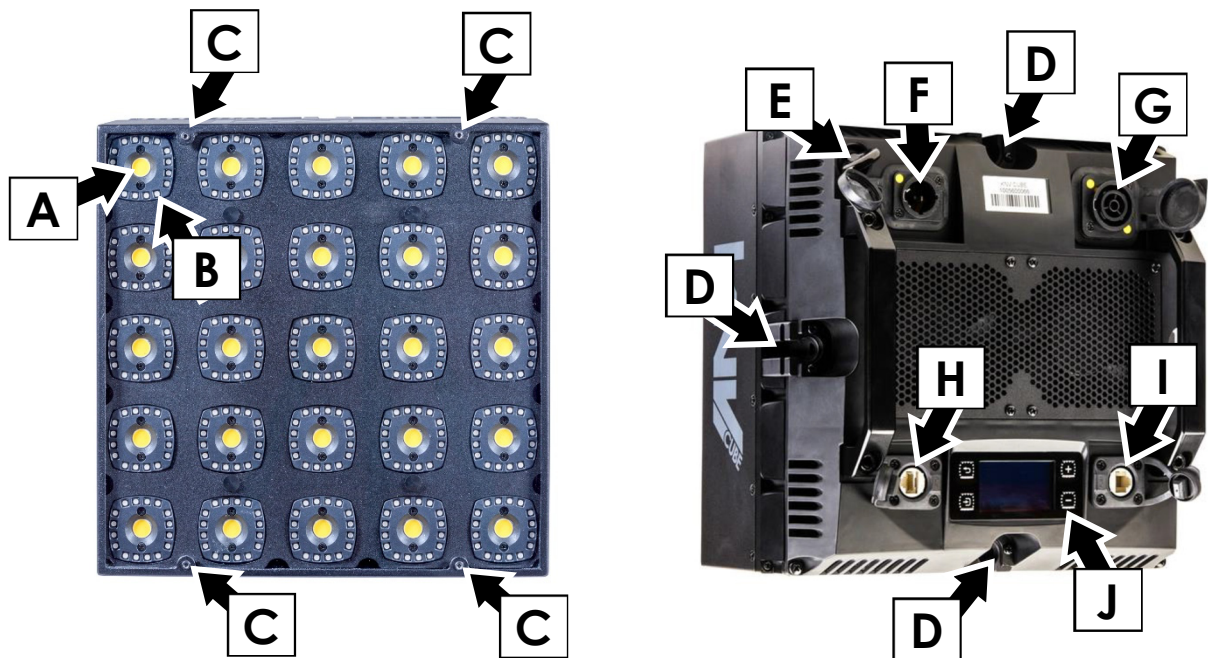

Figure 1. Cube overview

- A – White LED
- B – RGB LEDs
- C – Mounting points for optical accessories
- D – Mechanical connector attachment points
- E – Safety cable attachment point
- F – AC mains power IN (Neutrik powerCON TRUE1)
- G – AC mains power OUT / THRU (Neutrik powerCON TRUE1)
- H – Neutrik EtherCON port for control data (DMX/Art-Net/sACN in/out)
- I – Neutrik EtherCON port for control data (DMX/Art-Net/sACN in/out)
- J – Control panel with backlit LCD display

### 3. KNV Arc overview

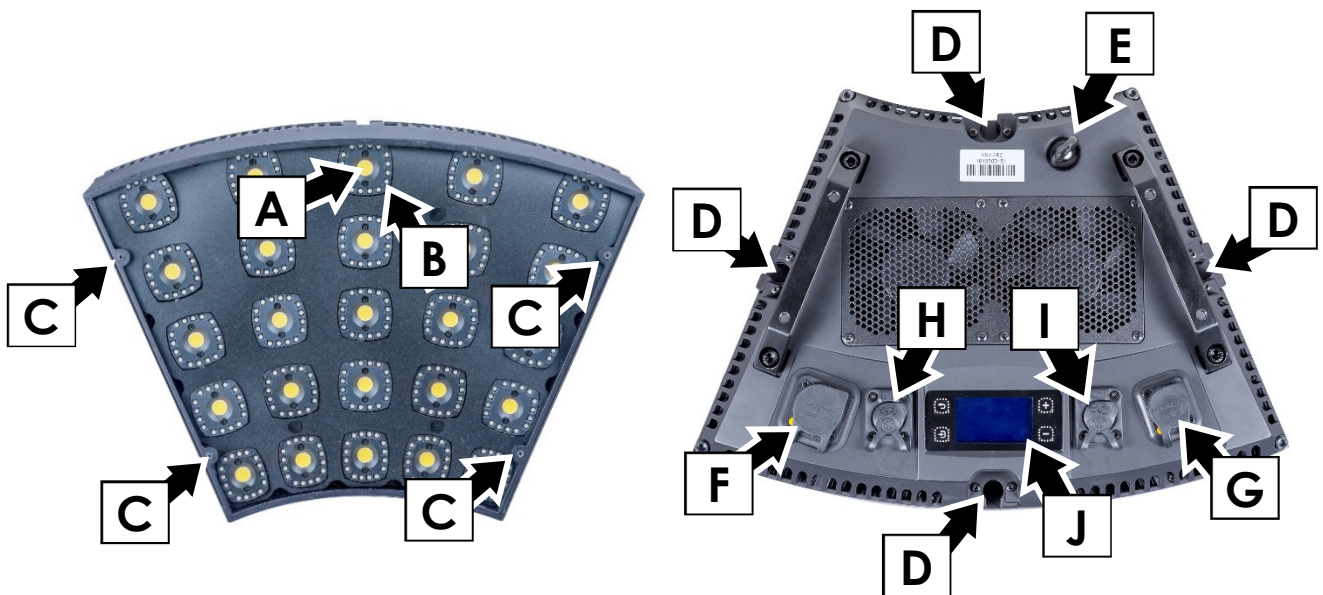

Figure 2. Arc overview

- A** – White LED
- B** – RGB LEDs
- C** – Mounting points for optical accessories
- D** – Mechanical connector attachment points
- E** – Safety cable attachment point
- F** – AC mains power IN (Neutrik powerCON TRUE1)
- G** – AC mains power OUT / THRU (Neutrik powerCON TRUE1)
- H** – Neutrik EtherCON port for control data (DMX/Art-Net/sACN in/out)
- I** – Neutrik EtherCON port for control data (DMX/Art-Net/sACN in/out)
- J** – Control panel with backlit LCD display

## 4. Features

The KNV from GLP is a powerful strobe/color effect lighting fixture. It is available in modular Cube and Arc variants that can be interlocked and combined to form lines and curves, giving enormous creative possibilities.

The fixture combines powerful white light output from a 5x5 matrix of 30-watt cool white LEDs with bright color output from a color wash panel that uses 400 high-quality RGB LEDs in circles around the white LEDs. Total luminous flux can exceed 50 000 lumens per module.

The LED array can be pixel-mapped through any standard controller. White and color output can be controlled separately or combined for stunning strobe, continuous output and wash effects. Using the powerful internal multilayer FX engine, complex dynamic effects can be created quickly with no need for a separate pixel-mapping media server.

The KNV can be used indoors in permanent and temporary installations. Its rugged construction and IP54 rating mean that it can also be used outdoors in temporary installations if precautions are taken to prevent immersion in water and damage from direct sunlight. It can be placed upright on a level surface or suspended from a suitable structure as described in the product's Quick Start and Installation Manual.

Four mounting points with M3 threaded holes are provided on the front of KNV fixtures for mounting optical accessories from GLP.

Power and data can be daisy-chained and products can be interlocked for ease of installation.

The KNV is not suitable for household use, for use in any location where unattended children have access to it, or for use in permanent outdoor installations.

### **White LEDs**

The KNV features a 5x5 matrix of cool white LEDs that produce powerful white light at 5000 K. The white LEDs can be controlled together or individually depending on the DMX control mode selected.

The white LEDs offer shutter and dimming effects including a powerful strobe, flashing at up to 16.67 Hz, or operate continuously to give high-output wash effects with a 120° beam angle.

You can also select from a wide range of pre-programmed dynamic FX patterns to run on the white LEDs.

### **Color LEDs**

The KNV's 400 RGB LEDs are arranged into circles of 16 LEDs that surround each white LED. The RGB LEDs can be controlled together or individually depending on the DMX control mode selected.

You can run a wide range of color effects (including strobe effects and dynamic FX patterns) on the RGB LEDs, or you can operate them continuously using RGB color mixing to provide a color wash with a 120° beam angle.

You can also use the RGB LEDs to add blue or red to the powerful white LEDs and adjust their color temperature.



### Pixel mapping

If you control the KNV's 5 x 5 matrix of LED blocks individually, pixels are numbered as shown below as seen from the front of the fixture:

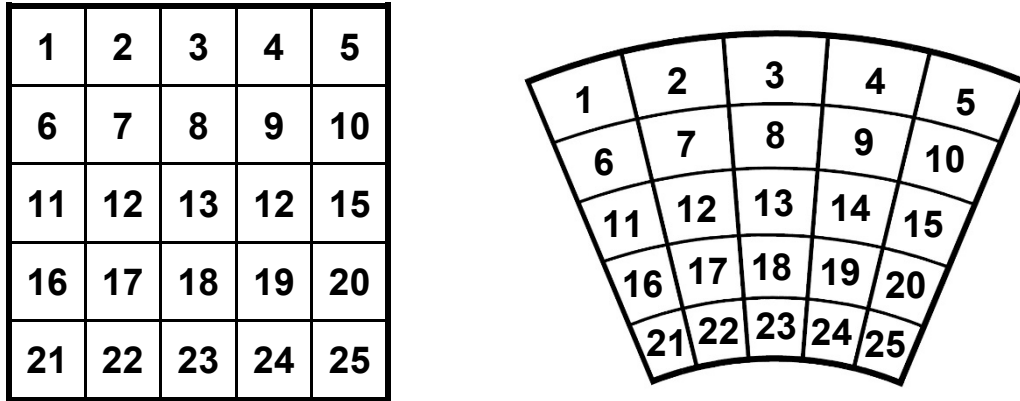

Figure 3. Pixel layout, Cube and Arc fixtures

### Pixel mirror

The *Pixel mirror* setting flips the numbering of the KNV's pixels right to left. This lets you set up symmetrical effects in multiple fixtures quickly without the need to reprogram cues.

Figure 3 above shows the default pixel orientation when *Pixel mirror* is set to **OFF** (Normal). Figure 4 below shows the pixel orientation when *Pixel mirror* is set to **ON**.

You can apply *Pixel mirror* using the *Control / Settings* DMX channel or in the control panel.

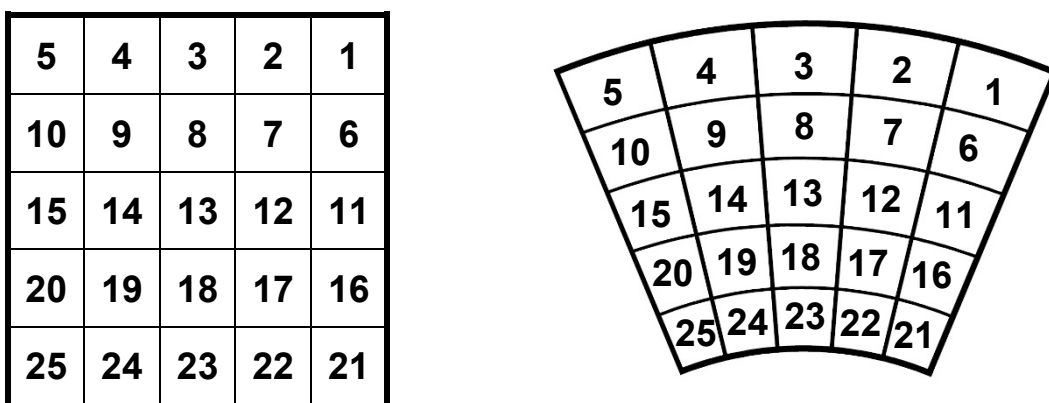

Figure 4. Pixel Mirror = ON

If you want to check a fixture's *Pixel mirror* status from the control desk, apply a Test pattern (see Figure 6 on page 15) on the *Control / Settings* DMX channel.

## Pixel orientation

In addition to the *Pixel mirror* setting described above, you can rotate the pixels in 90° steps using the *Control / Settings* DMX channel or the fixture's control panel.

## Dimming

See Figure 5. You can select from two dimming curves using the control panel or the *Control / Settings* DMX channel – **Linear** and **Soft**:

- Light output using the **Linear** curve will appear to increase and decrease evenly throughout the dimming range.
- The **Soft** curve gives finer control at low light levels (where the eye is more sensitive to changes in light level) and coarser control at high levels.

The default setting is **Soft**.

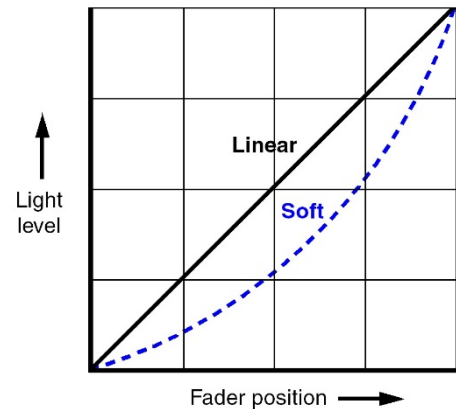

Figure 5. Dimming curves

## Flare effect

A feature which we call the *Flare effect* can be applied to flashes when they are activated on strobe channels. The *Flare effect* is an interference effect that you can superimpose onto a flash. This effect is particularly impressive when combined with increased flash length.

## Random pixel sparkle

The KNV's *Flare effect* channels include a *Random pixel* setting. This setting applies the flare effect to individual pixels at random, giving an impressive sparkling effect. Again, we recommend that you try combining this effect with increased flash length.

## Hyperspeed

Hyperspeed is a very fast flash rate on the Shutter effects channels that gives a very powerful effect.

## FX

The KNV's pre-programmed dynamic FX give you quick access to a wide range of dynamic patterns and movement options.

When FX are active, you can control them using six DMX channels:

- Five dedicated channels let you select an FX, set a crossfading speed, set pattern orientation, adjust FX length in pixels and set offsets.
- In addition to these channels, if an FX is active the third strobe channel becomes a sixth FX control channel and lets you adjust FX speed (see details below).

### Dedicated FX channels

- The first FX channel, the **FX Selection** channel, lets you choose and activate an FX from a list of dynamic FX patterns.

*If this channel is set to zero, the third strobe channel controls strobe flash rate. If an FX is selected on this channel, the third strobe channel controls FX speed.*

- The second FX channel, the **FX Crossfading** channel, sets the time it takes for the FX to fade out. You can set FX to crossfading and apply a crossfading time from fast to slow. You can also set FX to leave a tail behind them and apply a crossfading time for the tail from slow to fast.
- The third FX channel, the **FX Orientation** channel, lets you select from a long list of options for the orientation of the FX. Running the same FX but with different orientation options in multiple fixtures is a fast way to set up symmetrical and/or coordinated effects.
- The fourth FX channel, the **FX Offset** channel, lets you apply offsets to the FX, a feature which lets you quickly set up synchronized FX chases in multiple fixtures.

Setting an offset determines the pixel *in the pattern* (not the pixel on the fixture) where the FX pattern will start. For example, if you set the length of an FX pattern to 10 pixels and you apply an offset of 6 pixels, the fixture will blackout for the time it takes the FX pattern to run on pixels 1 – 5, then the FX pattern will appear on the fixture when the pattern reaches pixel 6.

- The fifth FX control channel, the **FX Length** channel, lets you set the total length in pixels of the FX pattern.

### FX speed control

If you select an FX on the *FX Selection* channel, the third strobe channel is redeployed and becomes the **FX Speed** control channel. Instead of controlling strobe flash rate, it now becomes the sixth FX control channel and lets you adjust the speed of the FX.

### Setting up FX chases

If you select the same FX with the same speed in multiple fixtures, you can use the other FX channels in combination to set up an FX chase across multiple fixtures:

- **FX Crossfading / Crossfading with tail** sets the rate at which one FX pattern step fades out before the next pattern step arrives.
- **FX Orientation** can be used to add variety to a chase or set up multiple coordinated chases in different groups of fixtures.
- **FX Offset** sets the pixel on which the FX pattern will start.

*An FX pattern with no offset starts on pixel 1. You will obtain this if you set the FX Offset channel to zero and also if you set the FX Offset channel to 001.*

- **FX Length** sets the number of pixels over which the FX pattern will run.

*The normal FX length is 5 pixels. You will obtain this 5-pixel length if you set the FX Length channel to zero. It is not possible to set FX Length to less than 5 pixels.*

*When you set up FX chases, you will normally achieve the best results by increasing FX length in steps of 5 pixels (one fixture).*

To obtain synchronized chases in multiple fixtures you must set up FX Length and FX Offset parameters in combination. Here is how FX Length and FX Offset work in a single fixture:

- FX Length = Off (DMX value zero on the *FX Length* DMX channel): The FX pattern will have the normal length of five pixels. It will start at pixel 1, run from pixel 1 to pixel 5 and then immediately start at pixel 1 again.
- FX Length = 30 (DMX value 030 on the *FX Length* DMX channel): The FX pattern will start at pixel 1, run from pixel 1 to pixel 5 and then black out for the time it takes to run the FX pattern on pixels 6 – 30.
- FX Offset = Off (DMX value zero on the *FX Offset* DMX channel): The FX pattern will start at pixel 1.
- FX Offset = 6 (DMX value 006 on the *FX Offset* DMX channel): The FX pattern will start at pixel 6. If you have set an FX length of 30, the pixels will black out for the time it takes to run the FX pattern on pixels 1 – 5, then run the FX pattern on pixels 6 – 10, then black out for the time it takes to run the FX pattern on pixels 11 – 30.

To create a single FX pattern chase that will run across an array of multiple fixtures, you need to:

- Set FX Length in all the fixtures to the total number of pixels that the pattern will run across, and
- Set FX Offset in each fixture in a sequence five pixels apart.

This means that, if you want an FX pattern to run across six fixtures in a horizontal row and return immediately to pixel 1 when it reaches pixel 30 at the end of the row, you must set FX Length to 30 on all six fixtures and set FX Offsets with a gap of five pixels between fixtures. To give a concrete example, here is how you must set up each fixture:

- Fixture 1: FX Length = 30, FX Offset = 1  
*FX will start at Pixel 1 of the 30 pixels in FX Length and run on pixels 1 - 5*
- Fixture 2: FX Length = 30, FX Offset = 6  
*FX will start at Pixel 6 of the 30 pixels in FX Length and run on pixels 6 - 10*
- Fixture 3: FX Length = 30, FX Offset = 11  
*FX will start at Pixel 11 of the 30 pixels in FX Length and run on pixels 11 – 15*
- Fixture 4: FX Length = 30, FX Offset = 16  
*FX will start at Pixel 16 of the 30 pixels in FX Length and run on pixels 16 - 20*
- Fixture 5: FX Length = 30, FX Offset = 21  
*FX will start at Pixel 21 of the 30 pixels in FX Length and run on pixels 21 - 25*
- Fixture 6: FX Length = 30, FX Offset = 26  
*FX will start at Pixel 26 of the 30 pixels in FX Length and run on pixels 26 - 30*

## **RGB color generator**

Where available, the RGB color generator effect gives instant access to automatic color effects such as random colors, ramp up/down colors and random pixel colors. These effects would be difficult to program on a DMX controller.

## **Extra shutter**

In DMX modes 1, 6 and 7, an extra shutter effect is available. You can choose whether this shutter effect should run on all LEDs (RGBW), on RGB LEDs only or on White LEDs only. You can make this choice via DMX on the Control / Settings channel in modes 1, 6 and 7 or using the fixture's control panel.

The default setting for the extra shutter effect is RGBW.

## **Behavior when the fixture is not receiving a DMX signal**

You can set the fixture to react in three different ways if no DMX signal is present (if the fixture is being controlled by DMX but the DMX signal stops, or if you apply power to the fixture when no DMX signal is present):

- **Hold** sets the fixture to continue obeying the last DMX values it received. This is the default setting.

If no DMX signal was being received, the fixture will black out.

- **Blackout** sets the fixture to black out.
- **Stand-alone** sets the fixture to show the scene that has been stored using *Capture scene* (see below). For safety reasons and to avoid unwanted surprises, the Stand-alone scene will always fade in slowly if it is activated.

To program the scene that the fixture will display if it is set to Stand-alone and no DMX signal is present, use the *Capture scene* command:

- **Capture scene** stores the scene that the fixture is currently displaying. Once stored, the scene is used as the fixture's *Stand-alone* scene.

All these settings are available via DMX on the *Control / Settings* channel and in the fixture's control panel.

To avoid any possibility of unexpected behavior from a powerful strobe light if the DMX signal fails, we recommend that you always set the fixture to *Blackout*.

## **Dimmer Flash mode**

A shortcut to creating single flashes is available if you activate *Dimmer Flash* using the *Control / Settings* DMX channel or the *Settings* menu in the fixture's control panel.

When *Dimmer Flash* mode is enabled, if the Flash rate channel (the third of the Strobe channels) is set to zero, any new DMX value that you input on the Intensity channel (the first of the Strobe channels) will produce a single flash. In effect, all you need to do is 'nudge the dimmer fader' to produce a flash.

If you activate this function, you can tap flashes in sync with a music beat, easily keeping track of changes in the beat.

## Display

The illuminated graphic LCD display with self-charging battery lets you change fixture settings even when the power is off. See Chapters 5 and 6 for more details.

Using the *Control / Settings* DMX channel or the fixture's control panel you can:

- Change the display orientation from Normal to Inverted for easier reading if the fixture is flown upside-down in a rig.
- Choose between three different display modes:
  - **Auto:** The display will automatically switch off after a few seconds if the fixture is receiving a valid control signal and has not detected an error. If the fixture is not receiving a valid control signal the display will flash. If the fixture has detected an error, the display will remain constantly on and show the error.
  - **On:** The display stays on constantly. This setting can be useful when you are configuring or servicing the fixture.
  - **Off:** The display will automatically switch off after a few seconds even if the fixture is not receiving a valid control signal or if it has detected an error.

## Fan modes

Four different cooling fan modes are available on the *Control / Settings* DMX channel and in the fixture's control panel. The modes let you choose cooling fan operation options depending on how you want to allocate priority between light output and fan noise:

- **Regulated mode** gives priority to light output and only operates fans as necessary. If the fixture is blacked out, fans run at minimum speed. When light output intensity is increased, temperature regulation increases fan speed to the level necessary to keep the fixture at optimum temperature.

If light output is set to maximum intensity but the fans can keep the fixture at optimum temperature, there will be no regulation of light intensity. If the fixture begins to exceed optimum temperature, light intensity will be reduced until optimum temperature can be maintained.

- **High mode** sets fans to constant high speed. This mode is optimized for maximum light output and suits operation in high ambient temperatures and/or where fan noise is not a critical issue. Light output intensity is smoothly reduced if it becomes necessary in order to keep fixture temperature at optimum level.

Besides maximizing light output in high ambient temperatures, you can use *high* mode to cool down a fixture quickly or to remove dust from cooling fans.

- **Medium mode** sets fans to constant medium speed. Light output intensity is smoothly reduced if it becomes necessary in order to keep fixture temperature at optimum level.

If you want to avoid any automatic reductions in output intensity that may occur in *regulated* mode (see above) or if fixture temperature exceeds optimum level, we recommend that you use *medium* mode in combination with one of the *Output limitation* levels available via DMX and in the fixture's control panel to keep the fixture in output/temperature balance.

- **Low mode** sets fans to constant low speed. This mode is optimized for minimum noise. Light output intensity is smoothly reduced if it becomes necessary in order to keep fixture temperature at optimum level.

If you want to avoid any automatic reductions in output intensity that may occur if fixture temperature exceeds optimum level, we recommend that you use *low mode* in combination with one of the *Output limitation* levels available via DMX and in the fixture's control panel to keep the fixture in output/temperature balance.

In all fan modes, if fixture temperature reaches an unsafe level, LEDs will be shut down for a period until the fans have brought the temperature down to a safe level.

### **Fixture information**

The **Information** menu in the control panel gives access to items of information from the fixture's sensors and memory. You can check temperature sensor readouts, see total operating hours counters and power cycle count, and see DMX signal quality data, for example.

### **Test pattern**

If you need to check a fixture's orientation, call up the test pattern on the *Control / Settings* DMX channel or in the fixture's control panel. If the fixture is oriented normally, the test pattern will appear as shown below:

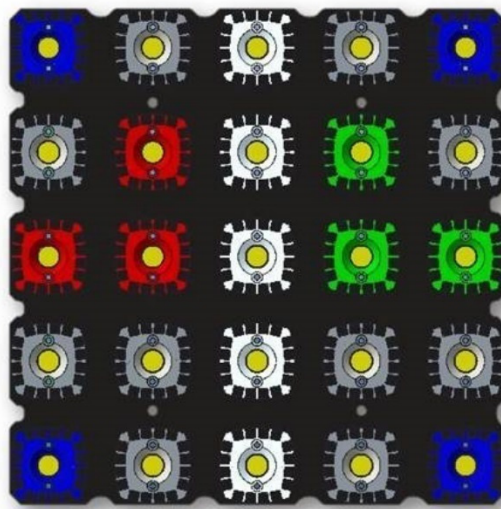

**Figure 6. Test pattern**

### **Custom settings and factory defaults**

You can customize fixture settings (DMX mode, Fan mode, Pixel orientation, etc.) via DMX or using the fixture's control panel. Custom settings are stored after a power off/on cycle and after a reset.

Two options are available in the fixture's control panel for deleting multiple custom settings and restoring defaults:

- **Load Setting Defaults** reloads all the fixture's factory default settings **except** DMX address, DMX mode and Control protocol. This option returns the fixture to baseline settings (default Fan mode, Output limitation, Pixel orientation, Dimmer curve, etc.) without affecting its basic configuration in an installation.
- **Load Factory Backup** reloads all the fixture's factory default settings **including** DMX address, DMX mode and Control Protocol. This option reinitializes the fixture completely and returns to its state when it left the factory.



## 5. Control menus and LCD display



**Warning!** DMX control is disabled when the control menus are active. Be prepared for the fixture to emit strong light as soon as you exit the control menus.

The control panel and LCD display provide access to user settings, readouts and utilities.

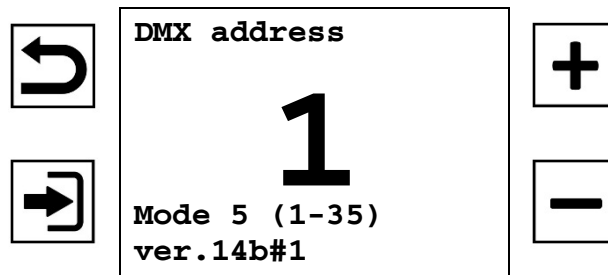

**Figure 7. Main screen**

The four control buttons have the following functions:



**Escape:** Go back one level and return to the top of the menu.



**Enter:** Activate the control panel if it is in sleep mode. Then enter a menu, select a setting or implement a command.



**Up:** Scroll up or increase a number.



**Down:** Scroll down or reduce a number.

When the fixture boots up, the control panel displays fixture information including firmware version and fixture hours before displaying the PCB reset status screen. After resetting, the panel displays the main screen. See Figure 7. The main screen displays the fixture's:

- DMX address
- DMX mode and channels occupied (in Figure 7, the fixture occupies DMX channels 1-35. Channel 36 is available for the next fixture on the DMX link)
- Firmware version and build data.

DMX control is disabled when the control menus are active.

See also the Display options on the *DMX Control / Settings* channel and in the *Display* control menu in the control panel.

## 6. Fixture control setup

To configure the KNV for use in a show or fixed installation, open the fixture's control menus and configure the fixture's DMX Address, Control Mode (DMX Mode) and Control Protocol (DMX, ArtNet or sACN).

If you are using ArtNet or sACN you need to set the fixture's IP address and SubNet Mask.

These settings will not be affected if you apply a *Load Default Settings* command in the fixture's control panel, but they **will** be returned to factory defaults if you apply a *Load Factory Backup* command in the fixture's control panel.

## 7. Control menu layout

Menus				Notes
DMX Start Address				
1-512				Enter DMX address
Control Mode				
Mode 1				RGBW + Shutter
Mode 2				W Strobe + RGB Strobe
Mode 3				RGB Strobe + 25x W
Mode 4				W Strobe + 25x RGB
<b>Mode 5</b>				Multilayer
Mode 6				25x RGBW 8-bit
Mode 7				25x RGBW 16-bit
Control Protocol				
Protocol Type	DMX			Control via DMX protocol
	<b>ArtNet</b>			Control via ArtNet protocol (default)
	sACN			Control via sACN protocol
Ethernet Configuration	Ethernet / Protocol Setup	Addressing Mode	Auto 2.X.X.X	Auto addressing in the range 2.X.X.X
			Auto 10.X.X.X	Auto addressing in the range 10.X.X.X
			Custom IP	Use custom IP address
			DHCP	Get IP address by DHCP
	Custom IP address		Enter IP address	Enter custom IP address
	Custom Subnet Mask		Enter Subnet Mask	Enter custom subnet mask
	ArtNet Universe		0 - 32768	Set ArtNet universe
	sACN Universe		1 - 63999	Set sACN universe
sACN UDP Port		2049.. <b>5568</b> ..65535	Select sACN port	
Fixture Settings				
Pixel Orientation	<b>Normal</b>			Set pixel orientation
	Rotate 90 deg.			
	Rotate 180 deg.			
	Rotate 270 deg.			
Pixel Mirrored	<b>OFF</b>			Set pixel flip right-to-left
	ON			
Output Limitation	Output Limitation - WHITE	<b>Off</b>		Set maximum output for White LEDs
		80% Output		
		60% Output		
		40% Output		
		20% Output		
		10% Output		

Output Limitation (continued)	Output Limitation - RGB	<b>Off</b>	Set maximum output for RGB LEDs
		80% Output	
		60% Output	
		40% Output	
		20% Output	
Dimmer Curve	<b>Soft</b>	Select dimming curve	
	Linear		
Dimm Flash	<b>Off</b>	Activate flash when dimmer channel value is moved	
	On		
Extra Shutter	<b>RGBW</b>	Sets which LEDs are used in the extra shutter effect that is available in DMX Modes 1, 6 and 7.	
	White		
	RGB		
No DMX	<b>Blackout</b>	Fixture blacks out when no DMX signal present	
	Hold	Fixture holds current scene when no DMX signal present	
	Stand Alone	Fixture goes to Stand-Alone scene when no DMX signal present	
	Capture Scene	<b>No</b>	Capture current scene for use as Stand-Alone scene
Yes			
Display Setting	Display Orientation	<b>Normal</b>	Invert display
		Upside-down	
	Display Mode	<b>Auto</b>	Display sleeps unless error detected or no valid control signal
		On	Display constantly on
		Off	Display off, even if error detected or no valid control signal
Fan Mode	<b>Regulated</b>	Fan speed temperature-regulated	
	High	Fan speed constant high	
	Medium	Fan speed constant medium	
	Low	Fan speed constant low	
Load Setting Defaults	<b>No</b>	Load factory default settings <u>apart from</u> DMX address, DMX mode, Control protocol	
	Yes		
<b>Manual Control</b>			
Reboot	<b>No</b>	Force fixture to reboot	
	Yes		
Manual DMX	Red	Send DMX value 0-65353	
	Green	Send DMX value 0-65353	
	Blue	Send DMX value 0-65353	
	Shutter	Send DMX value 0-65353	
	Capture Scene	<b>No</b>	Stores current control values as Stand-Alone scene
Yes			

Information			
Temperatures		Shows temperatures	
Output Limit		Shows current output limit	
Voltage		Shows master voltage	
		Shows driver voltage	
DMX Link Quality			
Network	TCP/IP		Shows Mode, IP Address, Sub Address, MAC Address (hex)
	Ethernet Port Status		Shows Ethernet Port Status
	ArtNet Status		Shows ArtNet Status
	sACN Status		Shows sACN Status
Serial Number		Shows fixture serial number	
Shape		Shows fixture type (Cube / Arc)	
Device Hours	Total (non resettable)		Shows total fixture hours (not resettable)
	Total (resettable)		Shows fixture hours since last counter reset
	Reset Counter	<b>No</b>	Sets resettable fixture hours counter to zero
Yes			
Power Cycles		Shows total power cycles (not resettable)	
Service			
Test Pattern	<b>Off</b>	Display test pattern on fixture	
	On		
Load Setting Defaults	<b>No</b>	Load factory default settings <u>apart from</u> DMX address, DMX mode, Control protocol	
	Yes		
Load Factory Backup	<b>No</b>	Load factory default settings <u>including</u> DMX address, DMX mode, Control protocol	
	Yes		

### Control Menus

Default settings are written in **BOLD type**.

## 8. DMX control modes

Seven DMX control modes are available in the KNV.

In all seven DMX modes, the last DMX channel is the *Control / Settings* channel. This channel lets you adjust fixture settings remotely from the DMX control desk.

- **DMX Mode 1** lets you control all 25 pixels together as a group with 16-bit resolution. A separate Shutter channel provides strobe, pixel and ramp-up/down effects. This extra shutter affects all white and all RGB LEDs by default, but you can change this setting via the Control/Settings DMX Channel or the fixture's control panel so that the shutter applies to white LEDs only or RGB LEDs only.
- **DMX Mode 2** splits the KNV into a White Strobe and a separate RGB Strobe, each with standard strobe light control channels: Intensity, Flash Rate and Flash Duration. In addition, the Flare effect and pre-programmed dynamic FX are available for each strobe.
- **DMX Mode 3** provides an RGB strobe plus 25 individually controllable white pixels. The RGB strobe has standard strobe control channels: Intensity, Flash Rate and Flash Duration. It also has the Flare effect and pre-programmed dynamic FX. The 25 individual white pixels have a separate Shutter channel with strobe, pixel and ramp-up/down effects.
- **DMX Mode 4** provides a White Strobe plus 25 individually controllable RGB pixels. The White strobe has standard strobe control channels: Intensity, Flash Rate and Flash Duration. It also has the Flare effect and pre-programmed dynamic FX. The 25 individual RGB pixels have a separate Shutter channel with strobe, pixel and ramp-up/down effects.
- **DMX Mode 5** provides three different layers:
  - The **Base Layer** has lowest priority (other layers override it), so it acts as a background layer. The Base layer has RGBW intensity control.
  - **Layer 2** has priority over the base layer, so it acts as a middle layer.
  - **Layer 3** has highest priority, so it acts as a top layer.
  - **Layers 2 and 3** both have standard RGBW strobe control channels plus the Flare effect and pre-programmed dynamic FX. Layers 2 and 3 also have a 16-bit Layer Master Channel that controls the transparency of the layer.

FX layer priorities work in true color, which means that colors are not mixed. If you run a red snake FX on Layer 2 over the top of a red background on the Base Layer, the snake will be blue, not a mix of blue and red.

Applying transparency to a layer allows the color of the background layer or the lower priority layer to shine through.

If you want to dim a layer's colors without color from lower priority layers shining through, reduce the intensity of the colors without applying transparency to the layer. If you reduce the intensity of all the colors to zero, you can run a black effect over the top of lower priority layers.

- In **DMX Modes 2, 3, 4 and 5** if no FX is selected (FX Selection channel is set to zero), the Flash rate channel controls the flash rate of the Strobe. If an FX is selected, the Flash rate channel is redeployed and controls the speed of the effect instead.

- **DMX Modes 6 and 7** give you individual control of 25 separate pixels with 8- or 16-bit resolution. A separate Shutter channel provides strobe, pixel and ramp-up/down effects. This extra shutter affects all the LEDs, both white and RGB, by default, but you can change this setting via the *Control / Settings* DMX Channel or the fixture's control panel so that the shutter applies to white LEDs only or to RGB LEDs only.

### ***Special notes on the DMX tables***

In the following DMX channel layout tables:

- Default settings are indicated with **bold type**.
- Where commands are marked with an asterisk \* you must send that value continuously for 3 seconds (or other duration if indicated in the table) to apply the command.
- Where LED orientation commands are marked with two asterisks \*\* the direction of FX pattern movement is reversed compared to the similar commands available earlier on the same channel. The orientation of the pattern itself is unchanged.

## Control channel layout

### DMX Mode 1: RGBW 16-bit

#### 10 DMX Channels

Channel	Command	DMX range	Percent	Default DMX	Fade	
<b>RGBW</b>						
1	<b>Red coarse</b>	All pixels, intensity 0-100%	0-65535	0-100%	0	Fade
2	<b>Red fine</b>					
3	<b>Green coarse</b>	All pixels, intensity 0-100%	0-65535	0-100%	0	Fade
4	<b>Green fine</b>					
5	<b>Blue coarse</b>	All pixels, intensity 0-100%	0-65535	0-100%	0	Fade
6	<b>Blue fine</b>					
7	<b>White coarse</b>	All pixels, intensity 0-100%	0-65535	0-100%	0	Fade
8	<b>White fine</b>					
9	<b>Shutter</b>	Shutter closed	0-4	0-1.6%	255	Snap
		Sync ramp up slow > fast	5-39	2.0-15.3%		Fade
		Sync ramp down slow > fast	40-74	15.7-29.0%		Fade
		Sync ramp up-down slow > fast	75-109	29.4-42.7%		Fade
		Sync double flash slow > fast	110-144	43.1-56.5%		Fade
		Random pixel slow > fast	145-179	56.9-70.2%		Fade
		Random strobe slow > fast	180-214	70.6-83.9%		Fade
		Sync strobe 0.289 > 16.67 Hz	215-249	84.3-97.6%		Fade
		Hyperspeed	250-252	98.0-98.8%		Snap
		Open	253-255	99.2-100%		Snap
<b>Control / Settings</b>						
10	<b>Control / Settings</b>	Idle	0-11	0-4.3%	0	Snap
		No function	12-38	4.7-14.9%		
		<b>Dimmer flash Off*</b>	39-41	15.3-16.1%		
		Dimmer flash On*	42-44	16.5-17.3%		
		No function	45-47	17.6-18.4%		
		<b>Dimming curve Soft*</b>	48-50	18.8-19.6%		
		Dimming curve Linear*	51-53	20.0-20.8%		
		No function	54-56	21.2-22.0%		
		<b>Extra Shutter RGBW*</b>	57-59	22.4-23.1%		
		Extra Shutter RGB only*	60-62	23.5-24.3%		
		Extra Shutter White only*	63-65	24.7-25.5%		
		No function	66-68	25.9-26.7%		
		<b>Fan mode regulated*</b>	69-71	27.1-27.8%		
		Fan mode high*	72-74	28.2-29.0%		
		Fan mode medium*	75-77	29.4-30.2%		
		Fan mode low*	78-80	30.6-31.4%		
		No function	81-83	31.8-32.5%		
		Display On*	84-86	32.9-33.7%		
		Display Off*	87-89	34.1-34.9%		
		<b>Display Auto*</b>	90-92	35.3-36.1%		
<b>Display invert Off*</b>	93-95	36.5-37.3%				
Display invert On*	96-98	37.6-38.4%				
No DMX = Capture scene*	99-101	38.8-39.6%				
No DMX = Stand-alone*	102-104	40.0-40.8%				
<b>No DMX = Blackout*</b>	105-107	41.2-42.0%				



	No DMX = Hold*	108-110	42.4-43.1%	
	Test pattern On*	111-113	43.5-44.3%	
	<b>Test pattern Off*</b>	114-116	44.7-45.5%	
	<b>Rotation Off*</b>	117-119	45.9-46.7%	
	Rotate 90° *	120-122	47.1-47.8%	
	Rotate 180° *	123-125	48.2-49.0%	
	Rotate 270° *	126-128	49.4-50.2%	
	<b>Pixel mirror Off*</b>	129-131	50.6-51.4%	
	Pixel mirror On*	132-134	51.8-52.5%	
	<b>White output limitation Off*</b>	135-137	52.9-53.7%	
	White output limitation 80%*	138-140	54.1-54.9%	
	White output limitation 60%*	141-143	55.3-56.1%	
	White output limitation 40%*	144-146	56.5-57.3%	
	White output limitation 20%*	147-149	57.6-58.4%	
	White output limitation 10%*	150-152	55.8-59.6%	
	No function	153-158	60.0-62.0%	
	<b>RGB output limitation Off%*</b>	159-161	62.4-63.1%	
	RGB output limitation 80%*	162-164	63.5-64.3%	
	RGB output limitation 60%*	165-167	64.7-65.5%	
	RGB output limitation 40%*	168-170	65.9-66.7%	
	RGB output limitation 20%*	171-173	67.1-67.8%	
	RGB output limitation 10%*	174-176	68.2-69.0%	
	No function	177-251	69.4-98.4%	
	Reboot fixture*	252-255	98.8-100%	

## DMX Mode 2: White strobe with FX, RGB with FX

### 23 DMX Channels

Channel	Command	DMX range	Percent	Default DMX	Fade	
<b>Channel group A: White strobe with FX</b>						
1	White LEDs intensity	Intensity 0-100%	0-255	0-100%	0 Fade	
2	White LEDs flash duration	Flash duration 7-650 ms	0-255	0-100%	0 Fade	
3	White LEDs flash rate (if FX are not active)	No flash	0-1	0-0.4%	0 Snap	
		Single flash if Dimmer Flash = ON and value is changed on Ch 1				
		Flash rate 0.289-16.67 Hz	2-250	0.8-98%		Fade
		Hyperspeed	251-252	98.4-98.8%		Snap
	Continuously on	253-255	99.2-100%	Snap		
	FX speed (if FX are active)	FX speed = stop	0-1	0-0.4%	Snap	
		FX speed = slow > fast	2-253	0.8-98.8%	Fade	
FX speed = stop		254-255	99.2-100%	Snap		
4	White LEDs Flare effect	Off	0-9	0-3.5%	0 Snap	
		Slow > fast	10-49	3.9-19.2%		Fade
		Off	50-59	19.6-23.1%		Snap
		Random slow > fast	60-109	23.5-42.7%		Fade
		Off	110-119	43.1-46.7%		Snap
		Random pixel slow > fast	120-169	47.1-66.3%		Fade
		Off	170-255	66.7-100%		Snap
5	White LEDs FX selection	FX Off	0-2	0-0.8%	0 Snap	
		Sync strobe - circle mask	3-5	1.2-2.0%		
		Sync strobe - 4 dot mask	6-8	2.4-3.1%		
		Sync strobe - 1 dot mask	9-11	3.5-4.3%		
		Random strobe - all	12-14	4.7-5.5%		
		Random strobe - circle mask	15-17	5.9-6.7%		
		Random strobe - 4 dot mask	18-20	7.1-7.8%		
		Random strobe - 1 dot mask	21-23	8.2-9.0%		
		Lite in/out - all	24-26	9.4-10.2%		
		Lite in/out - circle mask	27-29	10.6-11.4%		
		Lite in/out - 4 dot mask	30-32	11.8-12.6%		
		Lite in/out - 1 dot mask	33-35	12.9-13.7%		
		Snake	36-38	14.1-14.9%		
		Raindrops	39-41	15.3-16.1%		
		Random pixel	42-44	16.5-17.3%		
		Random fake x 2	45-47	17.6-18.4%		
		Random fake x 4	48-50	18.8-19.6%		
		Line	51-53	20.0-20.8%		
		Double line	54-56	21.2-22.0%		
		Corner to corner line	57-59	22.4-23.1%		
		Tilted double lines	60-62	23.5-24.3%		
		Tilted double lines in to out	63-65	24.7-25.5%		
		Center line running dot	66-68	25.9-26.7%		
		Middle line running dot	69-71	27.1-27.8%		
Outer line running dot	72-74	28.2-29.0%				
Corner to corner	75-77	29.4-30.2%				
Arrow	78-80	30.6-31.4%				
Wave	81-83	31.8-32.5%				
Wheel	84-86	32.9-33.7%				

		Half wheel	87-89	34.1-34.9%		
		Circling dot	90-92	35.3-36.1%		
		Outer circle	93-95	36.5-37.3%		
		Inner circle	96-98	37.6-38.4%		
		Outer 4 dots	99-101	38.8-39.6%		
		Outer single dot	102-104	40.0-40.8%		
		Middle single dot	105-107	41.2-42.0%		
		Spinning 2x1 dots	108-110	42.4-43.1%		
		Asymmetrical 4 dots	111-113	43.5-44.3%		
		Symmetrical 4 dots	114-116	44.7-45.5%		
		Square	117-119	45.9-46.7%		
		Inside out	120-122	47.1-48.8%		
		Inside out 2	123-125	48.2-49.0%		
		Abstract 1	126-128	49.4-50.2%		
		Abstract 2	129-131	50.6-51.4%		
		Abstract 3	132-134	51.8-52.5%		
		Hash tag	135-137	52.9-53.7%		
		Flip flop	138-140	54.1-54.9%		
		Jumping slash	141-143	55.3-56.1%		
		Jumping 'L'	144-146	56.5-57.3%		
		Jumping pins	147-149	57.6-58.4%		
		Off - No Strobe or Fx	150-255	58.8-100%		
6	White LEDs FX crossfade time	Off	0-1	0-0.4%	0	Snap
		Crossfade fast > slow	2-127	0.8-49.8%		Fade
		Crossfade and tail slow > fast	128-255	50.2-100%		Fade
7	White LEDs orientation	Off	0-4	0-1.6%	0	Snap
		Rotate 90°	5-9	2.0-3.5%		
		Rotate 180°	10-14	3.9-5.5%		
		Rotate 270°	15-19	5.9-7.5%		
		Horizontal flip	20-24	7.8-9.4%		
		Rotate 90° & vertical flip	25-29	9.8-11.4%		
		Rotate 180° & horizontal flip	30-34	11.8-13.3%		
		Rotate 270° & vertical flip	35-39	13.7-15.3%		
		Off	40-44	15.7-17.3%		
		Random rotate & flip	45-49	17.7-19.2%		
		Random position	50-54	19.6-21.2%		
		Fix 90° rotation & random position	55-59	21.6-23.1%		
		Fix 180° rotation & random position	60-64	23.5-25.1%		
		Fix 270° rotation & random position	65-69	25.5-27.1%		
		Off	70-74	27.5-29.0%		
		Bounce	75-79	29.4-31.0%		
		Bounce & rotate 90°	80-84	31.4-32.9%		
		Bounce & rotate 180°	85-89	33.3-34.9%		
		Bounce & rotate 270°	90-94	35.3-36.9%		
		Off	95-99	37.3-38.8%		
		Rotate CCW at end	100-104	39.2-40.8%		
		Rotate CW at end	105-109	41.2-42.7%		
		Random rotate at end	110-114	43.1-44.7%		
		Off	115-134	45.1-52.5%		
		Rotate 90° **	135-139	52.9-54.5%		
		Rotate 180° **	140-144	54.9-56.5%		
		Rotate 270° **	145-149	56.9-58.4%		
Horizontal flip **	150-154	58.8-60.4%				
Rotate 90° & vertical flip **	155-159	60.8-62.4%				
Rotate 180° & horizontal flip **	160-164	62.7-64.3%				

		Rotate 270° & vertical flip **	165-169	64.7-66.3%		
		Off	170-174	66.7-68.2%		
		Random Rotate & flip **	175-179	68.6-70.2%		
		Random position **	180-184	70.6-72.2%		
		Fix 90° rotation & random position **	185-189	72.5-74.1%		
		Fix 180° rotation & random position **	190-194	74.5-76.1%		
		Fix 270° rotation & random position **	195-199	76.5-78.0%		
		Off	200-204	78.4-80.0%		
		Bounce **	205-209	80.4-82.0%		
		Bounce & rotate 90° **	210-214	82.4-83.9%		
		Bounce & rotate 180° **	215-219	84.3-85.9%		
		Bounce & rotate 270° **	220-224	86.3-87.8%		
		Off	225-229	88.2-89.8%		
		Rotate CCW at end **	230-234	90.2-91.8%		
		Rotate CW at end **	235-239	92.2-93.7%		
		Random rotate at end **	240-244	94.1-95.7%		
		Off	245-255	96.1-100%		
<b>8</b>	<b>White LEDs FX offset</b>	0-100%	0-255	0-100%	0	Fade
<b>9</b>	<b>White LEDs FX length</b>	0-100%	0-255	0-100%	0	Fade
<b>Channel group B: RGB strobe with FX</b>						
<b>10</b>	<b>RGB LEDs dimmer</b>	Intensity 0-100%	0-255	0-100%	0	Fade
<b>11</b>	<b>RGB LEDs flash duration</b>	Flash duration 7-650 ms	0-255	0-100%	0	Fade
<b>12</b>	<b>RGB LEDs flash rate (if FX are not active)</b>	No flash	0-1	0-0.4%	0	Snap
		Flash rate 0.289-16.67 Hz	2-250	0.8-98%		Fade
		Hyperspeed	251-254	98.4-99.6%		Snap
		Continuously on	255	100%		Snap
	<b>FX speed (if FX are active)</b>	FX speed = stop	0-1	0-0.4%		Snap
		FX speed = slow > fast	2-253	0.8-98.8%		Fade
		FX speed = stop	254-255	99.2-100%		Snap
<b>13</b>	<b>Red</b>	Red intensity 0-100%	0-255	0-100%	255	Fade
<b>14</b>	<b>Green</b>	Green intensity 0-100%	0-255	0-100%	255	Fade
<b>15</b>	<b>Blue</b>	Blue intensity 0-100%	0-255	0-100%	255	Fade
<b>16</b>	<b>RGB LEDs Flare effect</b>	Off	0-9	0-3.5%	0	Snap
		Slow > fast	10-49	3.9-19.2%		Fade
		Off	50-59	19.6-23.1%		Snap
		Random slow > fast	60-109	23.5-42.7%		Fade
		Off	110-119	43.1-46.7%		Snap
		Random pixel slow > fast	120-169	47.1-66.3%		Fade
		Off	170-255	66.7-100%		Snap
<b>17</b>	<b>RGB LEDs FX selection</b>	FX Off	0-2	0-0.8%	0	Snap
		Sync strobe - circle mask	3-5	1.2-2.0%		
		Sync strobe - 4 dot mask	6-8	2.4-3.1%		
		Sync strobe - 1 dot mask	9-11	3.5-4.3%		
		Random strobe - all	12-14	4.7-5.5%		
		Random strobe - circle mask	15-17	5.9-6.7%		
		Random strobe - 4 dot mask	18-20	7.1-7.8%		
		Random strobe - 1 dot mask	21-23	8.2-9.0%		
		Lite in/out - all	24-26	9.4-10.2%		
		Lite in/out - circle mask	27-29	10.6-11.4%		
Lite in/out - 4 dot mask	30-32	11.8-12.6%				

		Lite in/out - 1 dot mask	33-35	12.9-13.7%		
		Snake	36-38	14.1-14.9%		
		Raindrops	39-41	15.3-16.1%		
		Random pixel	42-44	16.5-17.3%		
		Random fake x 2	45-47	17.6-18.4%		
		Random fake x 4	48-50	18.8-19.6%		
		Line	51-53	20.0-20.8%		
		Double line	54-56	21.2-22.0%		
		Corner to corner line	57-59	22.4-23.1%		
		Tilted double lines	60-62	23.5-24.3%		
		Tilted double lines in to out	63-65	24.7-25.5%		
		Center line running dot	66-68	25.9-26.7%		
		Middle line running dot	69-71	27.1-27.8%		
		Outer line running dot	72-74	28.2-29.0%		
		Corner to corner	75-77	29.4-30.2%		
		Arrow	78-80	30.6-31.4%		
		Wave	81-83	31.8-32.5%		
		Wheel	84-86	32.9-33.7%		
		Half wheel	87-89	34.1-34.9%		
		Circling dot	90-92	35.3-36.1%		
		Outer circle	93-95	36.5-37.3%		
		Inner circle	96-98	37.6-38.4%		
		Outer 4 dots	99-101	38.8-39.6%		
		Outer single dot	102-104	40.0-40.8%		
		Middle single dot	105-107	41.2-42.0%		
		Spinning 2x1 dots	108-110	42.4-43.1%		
		Asymmetrical 4 dots	111-113	43.5-44.3%		
		Symmetrical 4 dots	114-116	44.7-45.5%		
		Square	117-119	45.9-46.7%		
		Inside out	120-122	47.1-48.8%		
		Inside out 2	123-125	48.2-49.0%		
		Abstract 1	126-128	49.4-50.2%		
		Abstract 2	129-131	50.6-51.4%		
		Abstract 3	132-134	51.8-52.5%		
		Hash tag	135-137	52.9-53.7%		
		Flip flop	138-140	54.1-54.9%		
		Jumping slash	141-143	55.3-56.1%		
		Jumping 'L'	144-146	56.5-57.3%		
		Jumping pins	147-149	57.6-58.4%		
		Off - No Strobe or FX	150-255	58.8-100%		
18	RGB LEDs FX crossfade time	Off	0-1	0-0.4%	0	Snap
		Crossfade fast > slow	2-127	0.8-49.8%		Fade
		Crossfade and tail slow > fast	128-255	50.2-100%		Fade
19	RGB LEDs orientation	Off	0-4	0-1.6%	0	Snap
		Rotate 90°	5-9	2.0-3.5%		
		Rotate 180°	10-14	3.9-5.5%		
		Rotate 270°	15-19	5.9-7.5%		
		Horizontal flip	20-24	7.8-9.4%		
		Rotate 90° & vertical flip	25-29	9.8-11.4%		
		Rotate 180° & horizontal flip	30-34	11.8-13.3%		
		Rotate 270° & vertical flip	35-39	13.7-15.3%		
		Off	40-44	15.7-17.3%		
		Random rotate & flip	45-49	17.7-19.2%		
		Random position	50-54	19.6-21.2%		
Fix 90° rotation & random position	55-59	21.6-23.1%				

		Fix 180° rotation & random position	60-64	23.5-25.1%		
		Fix 270° rotation & random position	65-69	25.5-27.1%		
		Off	70-74	27.5-29.0%		
		Bounce	75-79	29.4-31.0%		
		Bounce & rotate 90°	80-84	31.4-32.9%		
		Bounce & rotate 180°	85-89	33.3-34.9%		
		Bounce & rotate 270°	90-94	35.3-36.9%		
		Off	95-99	37.3-38.8%		
		Rotate CCW at end	100-104	39.2-40.8%		
		Rotate CW at end	105-109	41.2-42.7%		
		Random rotate at end	110-114	43.1-44.7%		
		Off	115-134	45.1-52.5%		
		Rotate 90° **	135-139	52.9-54.5%		
		Rotate 180° **	140-144	54.9-56.5%		
		Rotate 270° **	145-149	56.9-58.4%		
		Horizontal flip **	150-154	58.8-60.4%		
		Rotate 90° & vertical flip **	155-159	60.8-62.4%		
		Rotate 180° & horizontal flip **	160-164	62.7-64.3%		
		Rotate 270° & vertical flip **	165-169	64.7-66.3%		
		Off	170-174	66.7-68.2%		
		Random Rotate & flip **	175-179	68.6-70.2%		
		Random position **	180-184	70.6-72.2%		
		Fix 90° rotation & random posn. **	185-189	72.5-74.1%		
		Fix 180° rotation & random posn. **	190-194	74.5-76.1%		
		Fix 270° rotation & random posn. **	195-199	76.5-78.0%		
		Off	200-204	78.4-80.0%		
		Bounce **	205-209	80.4-82.0%		
		Bounce & rotate 90° **	210-214	82.4-83.9%		
		Bounce & rotate 180° **	215-219	84.3-85.9%		
		Bounce & rotate 270° **	220-224	86.3-87.8%		
		Off	225-229	88.2-89.8%		
		Rotate CCW at end **	230-234	90.2-91.8%		
		Rotate CW at end **	235-239	92.2-93.7%		
		Random rotate at end **	240-244	94.1-95.7%		
		Off	245-255	96.1-100%		
<b>20</b>	<b>RGB LEDs FX offset</b>	0-100%	0-255	0-100%	0	Fade
<b>21</b>	<b>RGB LEDs FX length</b>	0-100%	0-255	0-100%	0	Fade
<b>22</b>	<b>RGB LEDs color generator</b>	Off	0-9	0-3.5%	0	Snap
		Random all pixels RGBCMY	10-19	3.9-7.5%		Snap
		Random single pixel RGBCMY	20-29	7.8-11.4%		Snap
		Random all pixels bright colors	30-39	11.8-15.3%		Snap
		Random single pixel bright colors	40-49	15.7-19.2%		Snap
		Red / Blue	50-59	19.6-23.1%		Snap
		Red / Green	60-69	23.5-27.1%		Snap
		Blue / Green	70-79	27.5-31.0%		Snap
		Yellow / Magenta	80-89	31.4-34.9%		Snap
		Yellow / Cyan	90-99	35.3-38.8%		Snap
		Cyan / Magenta	100-109	39.2-42.7%		Snap
		Yellow / Blue	110-119	43.1-46.7%		Snap
		Green / Magenta	120-129	47.1-50.6%		Snap
		Red / Green / Blue	130-139	51.0-54.5%		Snap
		Red / Yellow / Blue	140-149	54.9-58.4%		Snap
		Red / Green / Blue / Yellow / Magenta / Cyan	150-159	58.8%-62.4%		Snap

		Red / Green / Blue - Horizontal line	160-169	62.7-66.3%		Snap
		Red / Green / Blue - Vertical line	170-179	66.7-70.2%		Snap
		No function	180-219	70.6-85.9%		Snap
		Color scroll, slow -> fast	220-229	86.3-89.8%		Fade
		Lite in	230-239	90.2-93.7%		Snap
		Lite out	240-249	94.1-97.6%		Snap
		Off	250-255	98.0-100%		Snap
<b>Control / Settings</b>						
23	Control / Settings	Idle	0-11	0-4.3%	0	Snap
		No function	12-38	4.7-14.9%		
		<b>Dimmer flash Off*</b>	39-41	15.3-16.1%		
		Dimmer flash On*	42-44	16.5-17.3%		
		No function	45-47	17.6-18.4%		
		<b>Dimming curve Soft*</b>	48-50	18.8-19.6%		
		Dimming curve Linear*	51-53	20.0-20.8%		
		No function	54-68	21.2-26.7%		
		<b>Fan mode regulated*</b>	69-71	27.1-27.8%		
		Fan mode high*	72-74	28.2-29.0%		
		Fan mode medium*	75-77	29.4-30.2%		
		Fan mode low*	78-80	30.6-31.4%		
		No function	81-83	31.8-32.5%		
		Display On*	84-86	32.9-33.7%		
		Display Off*	87-89	34.1-34.9%		
		<b>Display Auto*</b>	90-92	35.3-36.1%		
		<b>Display invert Off*</b>	93-95	36.5-37.3%		
		Display invert On*	96-98	37.6-38.4%		
		No DMX = Capture scene*	99-101	38.8-39.6%		
		No DMX = Stand-alone*	102-104	40.0-40.8%		
		<b>No DMX = Blackout*</b>	105-107	41.2-42.0%		
		No DMX = Hold*	108-110	42.4-43.1%		
		Test pattern On*	111-113	43.5-44.3%		
		<b>Test pattern Off*</b>	114-116	44.7-45.5%		
		<b>Rotation Off*</b>	117-119	45.9-46.7%		
		Rotate 90° *	120-122	47.1-47.8%		
		Rotate 180° *	123-125	48.2-49.0%		
		Rotate 270° *	126-128	49.4-50.2%		
		<b>Pixel mirror Off*</b>	129-131	50.6-51.4%		
		Pixel mirror On*	132-134	51.8-52.5%		
		<b>White output limitation Off*</b>	135-137	52.9-53.7%		
		White output limitation 80%*	138-140	54.1-54.9%		
		White output limitation 60%*	141-143	55.3-56.1%		
		White output limitation 40%*	144-146	56.5-57.3%		
White output limitation 20%*	147-149	57.6-58.4%				
White output limitation 10%*	150-152	55.8-59.6%				
No function	153-158	60.0-62.0%				
<b>RGB output limitation Off*</b>	159-161	62.4-63.1%				
RGB output limitation 80%*	162-164	63.5-64.3%				
RGB output limitation 60%*	165-167	64.7-65.5%				
RGB output limitation 40%*	168-170	65.9-66.7%				
RGB output limitation 20%*	171-173	67.1-67.8%				
RGB output limitation 10%*	174-176	68.2-69.0%				
No function	177-251	69.4-98.4%				
Reboot fixture*	252-255	98.8-100%				

## DMX Mode 3: RGB strobe with FX, White 25-pixel

### 40 DMX Channels

Channel	Command	DMX range	Percent	Default DMX	Fade	
<b>Channel group A: RGB strobe with FX</b>						
1	RGB LEDs dimmer	Intensity 0-100%	0-255	0-100%	0	Fade
2	RGB LEDs flash duration	Flash duration 7-650 ms	0-255	0-100%	255	Fade
3	RGB LEDs flash rate (if FX not active)	No flash	0-1	0-0.4%	0	Snap
		Single flash if Dimmer Flash = ON and value is changed on Ch 1				
		Flash rate 0.289-16.67 Hz	2-250	0.8-98%		Fade
	Hyperspeed	251-254	98.4-99.6%	Snap		
	Continuously on	255	100%	Snap		
	RGB LEDs FX speed (if FX active)	FX speed = stop	0-1	0-0.4%		Snap
FX speed = slow > fast		2-253	0.8-98.8%	Fade		
FX speed = stop		254-255	99.2-100%	Snap		
4	Red	Red intensity 0-100%	0-255	0-100%	255	Fade
5	Green	Green intensity 0-100%	0-255	0-100%	255	Fade
6	Blue	Blue intensity 0-100%	0-255	0-100%	255	Fade
7	RGB LEDs Flare effect	Off	0-9	0-3.5%	0	Snap
		Slow > fast	10-49	3.9-19.2%		Fade
		Off	50-59	19.6-23.1%		Snap
		Random slow > fast	60-109	23.5-42.7%		Fade
		Off	110-119	43.1-46.7%		Snap
		Random pixel slow > fast	120-169	47.1-66.3%		Fade
		Off	170-255	66.7-100%		Snap
8	RGB LEDs FX selection	FX Off	0-2	0-0.8%	0	Snap
		Sync strobe - circle mask	3-5	1.2-2.0%		
		Sync strobe - 4 dot mask	6-8	2.4-3.1%		
		Sync strobe - 1 dot mask	9-11	3.5-4.3%		
		Random strobe - all	12-14	4.7-5.5%		
		Random strobe - circle mask	15-17	5.9-6.7%		
		Random strobe - 4 dot mask	18-20	7.1-7.8%		
		Random strobe - 1 dot mask	21-23	8.2-9.0%		
		Lite in/out - all	24-26	9.4-10.2%		
		Lite in/out - circle mask	27-29	10.6-11.4%		
		Lite in/out - 4 dot mask	30-32	11.8-12.6%		
		Lite in/out - 1 dot mask	33-35	12.9-13.7%		
		Snake	36-38	14.1-14.9%		
		Raindrops	39-41	15.3-16.1%		
		Random pixel	42-44	16.5-17.3%		
		Random fake x 2	45-47	17.6-18.4%		
		Random fake x 4	48-50	18.8-19.6%		
		Line	51-53	20.0-20.8%		
		Double line	54-56	21.2-22.0%		
		Corner to corner line	57-59	22.4-23.1%		
		Tilted double lines	60-62	23.5-24.3%		
Tilted double lines in to out	63-65	24.7-25.5%				
Center line running dot	66-68	25.9-26.7%				
Middle line running dot	69-71	27.1-27.8%				
Outer line running dot	72-74	28.2-29.0%				
Corner to corner	75-77	29.4-30.2%				



		Arrow	78-80	30.6-31.4%		
		Wave	81-83	31.8-32.5%		
		Wheel	84-86	32.9-33.7%		
		Half wheel	87-89	34.1-34.9%		
		Circling dot	90-92	35.3-36.1%		
		Outer circle	93-95	36.5-37.3%		
		Inner circle	96-98	37.6-38.4%		
		Outer 4 dots	99-101	38.8-39.6%		
		Outer single dot	102-104	40.0-40.8%		
		Middle single dot	105-107	41.2-42.0%		
		Spinning 2x1 dots	108-110	42.4-43.1%		
		Asymmetrical 4 dots	111-113	43.5-44.3%		
		Symmetrical 4 dots	114-116	44.7-45.5%		
		Square	117-119	45.9-46.7%		
		Inside out	120-122	47.1-48.8%		
		Inside out 2	123-125	48.2-49.0%		
		Abstract 1	126-128	49.4-50.2%		
		Abstract 2	129-131	50.6-51.4%		
		Abstract 3	132-134	51.8-52.5%		
		Hash tag	135-137	52.9-53.7%		
		Flip flop	138-140	54.1-54.9%		
		Jumping slash	141-143	55.3-56.1%		
		Jumping 'L'	144-146	56.5-57.3%		
		Jumping pins	147-149	57.6-58.4%		
Off - No Strobe or FX	150-255	58.8-100%				
<b>9</b>	<b>RGB LEDs FX crossfade time</b>	Off	0-1	0-0.4%	0	Snap Fade Fade
		Crossfade fast > slow	2-127	0.8-49.8%		
		Crossfade and tail slow > fast	128-255	50.2-100%		
<b>10</b>	<b>RGB LEDs orientation</b>	Off	0-4	0-1.6%	0	Snap
		Rotate 90°	5-9	2.0-3.5%		
		Rotate 180°	10-14	3.9-5.5%		
		Rotate 270°	15-19	5.9-7.5%		
		Horizontal flip	20-24	7.8-9.4%		
		Rotate 90° & vertical flip	25-29	9.8-11.4%		
		Rotate 180° & horizontal flip	30-34	11.8-13.3%		
		Rotate 270° & vertical flip	35-39	13.7-15.3%		
		Off	40-44	15.7-17.3%		
		Random rotate & flip	45-49	17.7-19.2%		
		Random position	50-54	19.6-21.2%		
		Fix 90° rotation & random position	55-59	21.6-23.1%		
		Fix 180° rotation & random position	60-64	23.5-25.1%		
		Fix 270° rotation & random position	65-69	25.5-27.1%		
		Off	70-74	27.5-29.0%		
		Bounce	75-79	29.4-31.0%		
		Bounce & rotate 90°	80-84	31.4-32.9%		
		Bounce & rotate 180°	85-89	33.3-34.9%		
		Bounce & rotate 270°	90-94	35.3-36.9%		
		Off	95-99	37.3-38.8%		
		Rotate CCW at end	100-104	39.2-40.8%		
		Rotate CW at end	105-109	41.2-42.7%		
		Random rotate at end	110-114	43.1-44.7%		
		Off	115-134	45.1-52.5%		
		Rotate 90° **	135-139	52.9-54.5%		
		Rotate 180° **	140-144	54.9-56.5%		
		Rotate 270° **	145-149	56.9-58.4%		

		Horizontal flip **	150-154	58.8-60.4%		
		Rotate 90° & vertical flip **	155-159	60.8-62.4%		
		Rotate 180° & horizontal flip **	160-164	62.7-64.3%		
		Rotate 270° & vertical flip **	165-169	64.7-66.3%		
		Off	170-174	66.7-68.2%		
		Random Rotate & flip **	175-179	68.6-70.2%		
		Random position **	180-184	70.6-72.2%		
		Fix 90° rotation & random posn. **	185-189	72.5-74.1%		
		Fix 180° rotation & random posn. **	190-194	74.5-76.1%		
		Fix 270° rotation & random posn. **	195-199	76.5-78.0%		
		Off	200-204	78.4-80.0%		
		Bounce **	205-209	80.4-82.0%		
		Bounce & rotate 90° **	210-214	82.4-83.9%		
		Bounce & rotate 180° **	215-219	84.3-85.9%		
		Bounce & rotate 270° **	220-224	86.3-87.8%		
		Off	225-229	88.2-89.8%		
		Rotate CCW at end **	230-234	90.2-91.8%		
		Rotate CW at end **	235-239	92.2-93.7%		
		Random rotate at end **	240-244	94.1-95.7%		
		Off	245-255	96.1-100%		
<b>11</b>	<b>RGB LEDs FX offset</b>	0-100%	0-255	0-100%	0	Fade
<b>12</b>	<b>RGB LEDs FX length</b>	0-100%	0-255	0-100%	0	Fade
<b>13</b>	<b>RGB LEDs color generator</b>	Off	0-9	0-3.5%	0	Snap
		Random all pixels RGBCMY	10-19	3.9-7.5%		Snap
		Random single pixel RGBCMY	20-29	7.8-11.4%		Snap
		Random all pixels bright colors	30-39	11.8-15.3%		Snap
		Random single pixel bright colors	40-49	15.7-19.2%		Snap
		Red / Blue	50-59	19.6-23.1%		Snap
		Red / Green	60-69	23.5-27.1%		Snap
		Blue / Green	70-79	27.5-31.0%		Snap
		Yellow / Magenta	80-89	31.4-34.9%		Snap
		Yellow / Cyan	90-99	35.3-38.8%		Snap
		Cyan / Magenta	100-109	39.2-42.7%		Snap
		Yellow / Blue	110-119	43.1-46.7%		Snap
		Green / Magenta	120-129	47.1-50.6%		Snap
		Red / Green / Blue	130-139	51.0-54.5%		Snap
		Red / Yellow / Blue	140-149	54.9-58.4%		Snap
		Red / Green / Blue / Yellow / Magenta / Cyan	150-159	58.8%-62.4%		Snap
		Red / Green / Blue - Horizontal line	160-169	62.7-66.3%		Snap
		Red / Green / Blue - Vertical line	170-179	66.7-70.2%		Snap
		No function	180-219	70.6-85.9%		Snap
		Color scroll, slow -> fast	220-229	86.3-89.8%		Fade
		Lite in	230-239	90.2-93.7%		Snap
		Lite out	240-249	94.1-97.6%		Snap
Off	250-255	98.0-100%	Snap			

<b>Channel group B: White 25-pixel</b>						
14	White pixel 1	Intensity 0-100%	0-255	0-100%	0	fade
15	White pixel 2	Intensity 0-100%	0-255	0-100%	0	fade
16	White pixel 3	Intensity 0-100%	0-255	0-100%	0	fade
17	White pixel 4	Intensity 0-100%	0-255	0-100%	0	fade
18	White pixel 5	Intensity 0-100%	0-255	0-100%	0	fade
19	White pixel 6	Intensity 0-100%	0-255	0-100%	0	fade
20	White pixel 7	Intensity 0-100%	0-255	0-100%	0	fade
21	White pixel 8	Intensity 0-100%	0-255	0-100%	0	fade
22	White pixel 9	Intensity 0-100%	0-255	0-100%	0	fade
23	White pixel 10	Intensity 0-100%	0-255	0-100%	0	fade
24	White pixel 11	Intensity 0-100%	0-255	0-100%	0	fade
25	White pixel 12	Intensity 0-100%	0-255	0-100%	0	fade
26	White pixel 13	Intensity 0-100%	0-255	0-100%	0	fade
27	White pixel 14	Intensity 0-100%	0-255	0-100%	0	fade
28	White pixel 15	Intensity 0-100%	0-255	0-100%	0	fade
29	White pixel 16	Intensity 0-100%	0-255	0-100%	0	fade
30	White pixel 17	Intensity 0-100%	0-255	0-100%	0	fade
31	White pixel 18	Intensity 0-100%	0-255	0-100%	0	fade
32	White pixel 19	Intensity 0-100%	0-255	0-100%	0	fade
33	White pixel 20	Intensity 0-100%	0-255	0-100%	0	fade
34	White pixel 21	Intensity 0-100%	0-255	0-100%	0	fade
35	White pixel 22	Intensity 0-100%	0-255	0-100%	0	fade
36	White pixel 23	Intensity 0-100%	0-255	0-100%	0	fade
37	White pixel 24	Intensity 0-100%	0-255	0-100%	0	fade
38	White pixel 25	Intensity 0-100%	0-255	0-100%	0	fade
39	White LEDs shutter	Shutter closed	0-4	0-1.6%	255	Snap
		Sync ramp up slow > fast	5-39	2.0-15.3%		Fade
		Sync ramp down slow > fast	40-74	15.7-29.0%		Fade
		Sync ramp up-down slow > fast	75-109	29.4-42.7%		Fade
		Sync double flash slow > fast	110-144	43.1-56.5%		Fade
		Pixel flare effect slow > fast	145-179	56.9-70.2%		Fade
		Random strobe slow > fast	180-214	70.6-83.9%		Fade
		Sync strobe 0.289 > 16.67 Hz	215-249	84.3-97.6%		Fade
		Hyperspeed	250-252	98.0-98.8%		Snap
Open	253-255	99.2-100%	Snap			
<b>Control / Settings</b>						
40	Control / Settings	Idle	0-11	0-4.3%	0	Snap
		No function	12-38	4.7-14.9%		
		<b>Dimmer flash Off*</b>	39-41	15.3-16.1%		
		Dimmer flash On*	42-44	16.5-17.3%		
		No function	45-47	17.6-18.4%		
		<b>Dimming curve Soft*</b>	48-50	18.8-19.6%		
		Dimming curve Linear*	51-53	20.0-20.8%		
		No function	54-68	21.2-26.7%		
		<b>Fan mode regulated*</b>	69-71	27.1-27.8%		
		Fan mode high*	72-74	28.2-29.0%		
		Fan mode medium*	75-77	29.4-30.2%		
		Fan mode low*	78-80	30.6-31.4%		
		No function	81-83	31.8-32.5%		
		Display On*	84-86	32.9-33.7%		
Display Off*	87-89	34.1-34.9%				
<b>Display Auto*</b>	90-92	35.3-36.1%				

	<b>Display invert Off*</b>	93-95	36.5-37.3%		
	Display invert On*	96-98	37.6-38.4%		
	No DMX = Capture scene*	99-101	38.8-39.6%		
	No DMX = Stand-alone*	102-104	40.0-40.8%		
	<b>No DMX = Blackout*</b>	105-107	41.2-42.0%		
	No DMX = Hold*	108-110	42.4-43.1%		
	Test pattern On*	111-113	43.5-44.3%		
	<b>Test pattern Off*</b>	114-116	44.7-45.5%		
	<b>Rotation Off*</b>	117-119	45.9-46.7%		
	Rotate 90° *	120-122	47.1-47.8%		
	Rotate 180° *	123-125	48.2-49.0%		
	Rotate 270° *	126-128	49.4-50.2%		
	<b>Pixel mirror Off*</b>	129-131	50.6-51.4%		
	Pixel mirror On*	132-134	51.8-52.5%		
	<b>White output limitation Off*</b>	135-137	52.9-53.7%		
	White output limitation 80%*	138-140	54.1-54.9%		
	White output limitation 60%*	141-143	55.3-56.1%		
	White output limitation 40%*	144-146	56.5-57.3%		
	White output limitation 20%*	147-149	57.6-58.4%		
	White output limitation 10%*	150-152	55.8-59.6%		
	No function	153-158	60.0-62.0%		
	<b>RGB output limitation Off%*</b>	159-161	62.4-63.1%		
	RGB output limitation 80%*	162-164	63.5-64.3%		
	RGB output limitation 60%*	165-167	64.7-65.5%		
	RGB output limitation 40%*	168-170	65.9-66.7%		
	RGB output limitation 20%*	171-173	67.1-67.8%		
	RGB output limitation 10%*	174-176	68.2-69.0%		
	No function	177-251	69.4-98.4%		
	Reboot fixture*	252-255	98.8-100%		

## DMX Mode 4: White strobe with FX, RGB 25-pixel

### 86 DMX Channels

Channel	Command	DMX range	Percent	Default DMX	Fade	
<b>Channel group A: White strobe with FX</b>						
1	White LEDs dimmer	Intensity 0-100%	0-255	0-100%	0 Fade	
2	White LEDs flash duration	Flash duration 7-650 ms	0-255	0-100%	0 Fade	
3	White LEDs flash rate (if FX are not active)	No flash	0-1	0-0.4%	0	Snap
		Single flash if Dimmer Flash = ON and value is changed on Ch 1				
		Flash rate 0.289-16.67 Hz	2-250	0.8-98%		Fade
		Hyperspeed	251-252	98.4-98.8%		Snap
	Continuously on	253-255	99.2-100%	Snap		
	FX speed (if FX are active)	FX speed = stop	0-1	0-0.4%	Snap	
		FX speed = slow > fast	2-253	0.8-98.8%	Fade	
FX speed = stop		254-255	99.2-100%	Snap		
4	White LEDs Flare effect	Off	0-9	0-3.5%	0	Snap
		Slow > fast	10-49	3.9-19.2%		Fade
		Off	50-59	19.6-23.1%		Snap
		Random slow > fast	60-109	23.5-42.7%		Fade
		Off	110-119	43.1-46.7%		Snap
		Random pixel slow > fast	120-169	47.1-66.3%		Fade
		Off	170-255	66.7-100%		Snap
5	White LEDs FX selection	FX Off	0-2	0-0.8%	0	Snap
		Sync strobe - circle mask	3-5	1.2-2.0%		
		Sync strobe - 4 dot mask	6-8	2.4-3.1%		
		Sync strobe - 1 dot mask	9-11	3.5-4.3%		
		Random strobe - all	12-14	4.7-5.5%		
		Random strobe - circle mask	15-17	5.9-6.7%		
		Random strobe - 4 dot mask	18-20	7.1-7.8%		
		Random strobe - 1 dot mask	21-23	8.2-9.0%		
		Lite in/out - all	24-26	9.4-10.2%		
		Lite in/out - circle mask	27-29	10.6-11.4%		
		Lite in/out - 4 dot mask	30-32	11.8-12.6%		
		Lite in/out - 1 dot mask	33-35	12.9-13.7%		
		Snake	36-38	14.1-14.9%		
		Raindrops	39-41	15.3-16.1%		
		Random pixel	42-44	16.5-17.3%		
		Random fake x 2	45-47	17.6-18.4%		
		Random fake x 4	48-50	18.8-19.6%		
		Line	51-53	20.0-20.8%		
		Double line	54-56	21.2-22.0%		
		Corner to corner line	57-59	22.4-23.1%		
		Tilted double lines	60-62	23.5-24.3%		
		Tilted double lines in to out	63-65	24.7-25.5%		
		Center line running dot	66-68	25.9-26.7%		
		Middle line running dot	69-71	27.1-27.8%		
		Outer line running dot	72-74	28.2-29.0%		
		Corner to corner	75-77	29.4-30.2%		
		Arrow	78-80	30.6-31.4%		
Wave	81-83	31.8-32.5%				
Wheel	84-86	32.9-33.7%				

		Half wheel	87-89	34.1-34.9%		
		Circling dot	90-92	35.3-36.1%		
		Outer circle	93-95	36.5-37.3%		
		Inner circle	96-98	37.6-38.4%		
		Outer 4 dots	99-101	38.8-39.6%		
		Outer single dot	102-104	40.0-40.8%		
		Middle single dot	105-107	41.2-42.0%		
		Spinning 2x1 dots	108-110	42.4-43.1%		
		Asymmetrical 4 dots	111-113	43.5-44.3%		
		Symmetrical 4 dots	114-116	44.7-45.5%		
		Square	117-119	45.9-46.7%		
		Inside out	120-122	47.1-48.8%		
		Inside out 2	123-125	48.2-49.0%		
		Abstract 1	126-128	49.4-50.2%		
		Abstract 2	129-131	50.6-51.4%		
		Abstract 3	132-134	51.8-52.5%		
		Hash tag	135-137	52.9-53.7%		
		Flip flop	138-140	54.1-54.9%		
		Jumping slash	141-143	55.3-56.1%		
		Jumping 'L'	144-146	56.5-57.3%		
		Jumping pins	147-149	57.6-58.4%		
		Off - No Strobe, no FX	150-255	58.8-100%		
6	White LEDs FX crossfade time	Off	0-1	0-0.4%	0	Snap
		Crossfade fast > slow	2-127	0.8-49.8%		Fade
		Crossfade and tail slow > fast	128-255	50.2-100%		Fade
7	White LEDs orientation	Off	0-4	0-1.6%	0	Snap
		Rotate 90°	5-9	2.0-3.5%		
		Rotate 180°	10-14	3.9-5.5%		
		Rotate 270°	15-19	5.9-7.5%		
		Horizontal flip	20-24	7.8-9.4%		
		Rotate 90° & vertical flip	25-29	9.8-11.4%		
		Rotate 180° & horizontal flip	30-34	11.8-13.3%		
		Rotate 270° & vertical flip	35-39	13.7-15.3%		
		Off	40-44	15.7-17.3%		
		Random rotate & flip	45-49	17.7-19.2%		
		Random position	50-54	19.6-21.2%		
		Fix 90° rotation & random position	55-59	21.6-23.1%		
		Fix 180° rotation & random position	60-64	23.5-25.1%		
		Fix 270° rotation & random position	65-69	25.5-27.1%		
		Off	70-74	27.5-29.0%		
		Bounce	75-79	29.4-31.0%		
		Bounce & rotate 90°	80-84	31.4-32.9%		
		Bounce & rotate 180°	85-89	33.3-34.9%		
		Bounce & rotate 270°	90-94	35.3-36.9%		
		Off	95-99	37.3-38.8%		
		Rotate CCW at end	100-104	39.2-40.8%		
		Rotate CW at end	105-109	41.2-42.7%		
		Random rotate at end	110-114	43.1-44.7%		
		Off	115-134	45.1-52.5%		
		Rotate 90° **	135-139	52.9-54.5%		
		Rotate 180° **	140-144	54.9-56.5%		
		Rotate 270° **	145-149	56.9-58.4%		
		Horizontal flip **	150-154	58.8-60.4%		
		Rotate 90° & vertical flip **	155-159	60.8-62.4%		
Rotate 180° & horizontal flip **	160-164	62.7-64.3%				

		Rotate 270° & vertical flip **	165-169	64.7-66.3%		
		Off	170-174	66.7-68.2%		
		Random Rotate & flip **	175-179	68.6-70.2%		
		Random position **	180-184	70.6-72.2%		
		Fix 90° rotation & random posn. **	185-189	72.5-74.1%		
		Fix 180° rotation & random posn. **	190-194	74.5-76.1%		
		Fix 270° rotation & random posn. **	195-199	76.5-78.0%		
		Off	200-204	78.4-80.0%		
		Bounce **	205-209	80.4-82.0%		
		Bounce & rotate 90° **	210-214	82.4-83.9%		
		Bounce & rotate 180° **	215-219	84.3-85.9%		
		Bounce & rotate 270° **	220-224	86.3-87.8%		
		Off	225-229	88.2-89.8%		
		Rotate CCW at end **	230-234	90.2-91.8%		
		Rotate CW at end **	235-239	92.2-93.7%		
		Random rotate at end **	240-244	94.1-95.7%		
		Off	245-255	96.1-100%		
<b>8</b>	<b>White LEDs FX offset</b>	0-100%	0-255	0-100%	0	Fade
<b>9</b>	<b>White LEDs FX length</b>	0-100%	0-255	0-100%	0	Fade
<b>Channel group B: RGB 25-pixel</b>						
<b>10</b>	<b>RGB Pixel 1</b>	Red	0-100%	0-255	255	Fade
<b>11</b>		Green	0-100%	0-255	255	Fade
<b>12</b>		Blue	0-100%	0-255	255	Fade
<b>13</b>	<b>RGB Pixel 2</b>	Red	0-100%	0-255	255	Fade
<b>14</b>		Green	0-100%	0-255	255	Fade
<b>15</b>		Blue	0-100%	0-255	255	Fade
<b>16</b>	<b>RGB Pixel 3</b>	Red	0-100%	0-255	255	Fade
<b>17</b>		Green	0-100%	0-255	255	Fade
<b>18</b>		Blue	0-100%	0-255	255	Fade
<b>19</b>	<b>RGB Pixel 4</b>	Red	0-100%	0-255	255	Fade
<b>20</b>		Green	0-100%	0-255	255	Fade
<b>21</b>		Blue	0-100%	0-255	255	Fade
<b>22</b>	<b>RGB Pixel 5</b>	Red	0-100%	0-255	255	Fade
<b>23</b>		Green	0-100%	0-255	255	Fade
<b>24</b>		Blue	0-100%	0-255	255	Fade
<b>25</b>	<b>RGB Pixel 6</b>	Red	0-100%	0-255	255	Fade
<b>26</b>		Green	0-100%	0-255	255	Fade
<b>27</b>		Blue	0-100%	0-255	255	Fade
<b>28</b>	<b>RGB Pixel 7</b>	Red	0-100%	0-255	255	Fade
<b>29</b>		Green	0-100%	0-255	255	Fade
<b>30</b>		Blue	0-100%	0-255	255	Fade
<b>31</b>	<b>RGB Pixel 8</b>	Red	0-100%	0-255	255	Fade
<b>32</b>		Green	0-100%	0-255	255	Fade
<b>33</b>		Blue	0-100%	0-255	255	Fade
<b>34</b>	<b>RGB Pixel 9</b>	Red	0-100%	0-255	255	Fade
<b>35</b>		Green	0-100%	0-255	255	Fade
<b>36</b>		Blue	0-100%	0-255	255	Fade
<b>37</b>	<b>RGB Pixel 10</b>	Red	0-100%	0-255	255	Fade
<b>38</b>		Green	0-100%	0-255	255	Fade
<b>39</b>		Blue	0-100%	0-255	255	Fade

40	RGB Pixel 11	Red	0-100%	0-255	255	Fade
41		Green	0-100%	0-255	255	Fade
42		Blue	0-100%	0-255	255	Fade
43	RGB Pixel 12	Red	0-100%	0-255	255	Fade
44		Green	0-100%	0-255	255	Fade
45		Blue	0-100%	0-255	255	Fade
46	RGB Pixel 13	Red	0-100%	0-255	255	Fade
47		Green	0-100%	0-255	255	Fade
48		Blue	0-100%	0-255	255	Fade
49	RGB Pixel 14	Red	0-100%	0-255	255	Fade
50		Green	0-100%	0-255	255	Fade
51		Blue	0-100%	0-255	255	Fade
52	RGB Pixel 15	Red	0-100%	0-255	255	Fade
53		Green	0-100%	0-255	255	Fade
54		Blue	0-100%	0-255	255	Fade
55	RGB Pixel 16	Red	0-100%	0-255	255	Fade
56		Green	0-100%	0-255	255	Fade
57		Blue	0-100%	0-255	255	Fade
58	RGB Pixel 17	Red	0-100%	0-255	255	Fade
59		Green	0-100%	0-255	255	Fade
60		Blue	0-100%	0-255	255	Fade
61	RGB Pixel 18	Red	0-100%	0-255	255	Fade
62		Green	0-100%	0-255	255	Fade
63		Blue	0-100%	0-255	255	Fade
64	RGB Pixel 19	Red	0-100%	0-255	255	Fade
65		Green	0-100%	0-255	255	Fade
66		Blue	0-100%	0-255	255	Fade
67	RGB Pixel 20	Red	0-100%	0-255	255	Fade
68		Green	0-100%	0-255	255	Fade
69		Blue	0-100%	0-255	255	Fade
70	RGB Pixel 21	Red	0-100%	0-255	255	Fade
71		Green	0-100%	0-255	255	Fade
72		Blue	0-100%	0-255	255	Fade
73	RGB Pixel 22	Red	0-100%	0-255	255	Fade
74		Green	0-100%	0-255	255	Fade
75		Blue	0-100%	0-255	255	Fade
76	RGB Pixel 23	Red	0-100%	0-255	255	Fade
77		Green	0-100%	0-255	255	Fade
78		Blue	0-100%	0-255	255	Fade
79	RGB Pixel 24	Red	0-100%	0-255	255	Fade
80		Green	0-100%	0-255	255	Fade
81		Blue	0-100%	0-255	255	Fade
82	RGB Pixel 25	Red	0-100%	0-255	255	Fade
83		Green	0-100%	0-255	255	Fade
84		Blue	0-100%	0-255	255	Fade
85	RGB LEDs shutter	Shutter closed	0-4	0-1.6%	255	Snap
		Sync ramp up slow > fast	5-39	2.0-15.3%		Fade
		Sync ramp down slow > fast	40-74	15.7-29.0%		Fade
		Sync ramp up-down slow > fast	75-109	29.4-42.7%		Fade
		Sync double flash slow > fast	110-144	43.1-56.5%		Fade
		Pixel flare effect slow > fast	145-179	56.9-70.2%		Fade
		Random strobe slow > fast	180-214	70.6-83.9%		Fade
		Sync strobe 0.289 > 16.67 Hz	215-249	84.3-97.6%		Fade



		Hyperspeed	250-252	98.0-98.8%		Snap
		Open	253-255	99.2-100%		Snap

Control / Settings						
86	Control / Settings	Idle	0-11	0-4.3%	0	Snap
		No function	12-38	4.7-14.9%		
		<b>Dimmer flash Off*</b>	39-41	15.3-16.1%		
		Dimmer flash On*	42-44	16.5-17.3%		
		No function	45-47	17.6-18.4%		
		<b>Dimming curve Soft*</b>	48-50	18.8-19.6%		
		Dimming curve Linear*	51-53	20.0-20.8%		
		No function	54-68	21.2-26.7%		
		<b>Fan mode regulated*</b>	69-71	27.1-27.8%		
		Fan mode high*	72-74	28.2-29.0%		
		Fan mode medium*	75-77	29.4-30.2%		
		Fan mode low*	78-80	30.6-31.4%		
		No function	81-83	31.8-32.5%		
		Display On*	84-86	32.9-33.7%		
		Display Off*	87-89	34.1-34.9%		
		<b>Display Auto*</b>	90-92	35.3-36.1%		
		<b>Display invert Off*</b>	93-95	36.5-37.3%		
		Display invert On*	96-98	37.6-38.4%		
		No DMX = Capture scene*	99-101	38.8-39.6%		
		No DMX = Stand-alone*	102-104	40.0-40.8%		
		<b>No DMX = Blackout*</b>	105-107	41.2-42.0%		
		No DMX = Hold*	108-110	42.4-43.1%		
		Test pattern On*	111-113	43.5-44.3%		
		<b>Test pattern Off*</b>	114-116	44.7-45.5%		
		<b>Rotation Off*</b>	117-119	45.9-46.7%		
		Rotate 90° *	120-122	47.1-47.8%		
		Rotate 180° *	123-125	48.2-49.0%		
		Rotate 270° *	126-128	49.4-50.2%		
		<b>Pixel mirror Off*</b>	129-131	50.6-51.4%		
		Pixel mirror On*	132-134	51.8-52.5%		
		<b>White output limitation Off*</b>	135-137	52.9-53.7%		
		White output limitation 80%*	138-140	54.1-54.9%		
		White output limitation 60%*	141-143	55.3-56.1%		
		White output limitation 40%*	144-146	56.5-57.3%		
		White output limitation 20%*	147-149	57.6-58.4%		
		White output limitation 10%*	150-152	58.8-59.6%		
		No function	153-158	60.0-62.0%		
		<b>RGB output limitation Off%*</b>	159-161	62.4-63.1%		
		RGB output limitation 80%*	162-164	63.5-64.3%		
		RGB output limitation 60%*	165-167	64.7-65.5%		
		RGB output limitation 40%*	168-170	65.9-66.7%		
RGB output limitation 20%*	171-173	67.1-67.8%				
RGB output limitation 10%*	174-176	68.2-69.0%				
No function	177-251	69.4-98.4%				
Reboot fixture*	252-255	98.8-100%				

## DMX Mode 5: Multi-layer RGBW with FX

### 35 DMX Channels

Channel	Command	DMX range	Percent	Default DMX	Fade	
<b>Channel group A: Base layer RGBW (low priority)</b>						
1	<b>Red</b>	Intensity 0-100%	0-255	0-100%	0 Fade	
2	<b>Green</b>	Intensity 0-100%	0-255	0-100%	0 Fade	
3	<b>Blue</b>	Intensity 0-100%	0-255	0-100%	0 Fade	
4	<b>White</b>	Intensity 0-100%	0-255	0-100%	0 Fade	
<b>Channel group B: Layer 2 RGBW strobe with FX (medium priority, true color)</b>						
5	<b>Layer 2 master (16-bit)</b>	Layer 2 = transparent	0-1	0-0.4%	0	Snap
6		Layer 2 intensity 0-100%	2-65535	0.8-100%		Fade
7	<b>Layer 2 flash duration</b>	7-650 ms	0-255	0-100%	0	Fade
8	<b>Layer 2 flash rate (if FX not active)</b>	No flash	0-1	0-0.4%	0	Snap
		Single flash if Dimmer Flash = ON and value is changed on Ch 5				
		Flash rate 0.289-16.67 Hz	2-250	0.8-98%		Fade
		Hyperspeed	251-252	98.4-98.8%		Snap
	Continuously on	253-255	99.2-100%	Snap		
	<b>Layer 2 FX speed (If FX active)</b>	FX speed = stop	0-1	0-0.4%		Snap
FX speed = slow > fast		2-253	0.8-98.8%	Fade		
FX speed = stop		254-255	99.2-100%	Snap		
9	<b>Layer 2 Flare effect</b>	Off	0-9	0-3.5%	0	Snap
		Slow > fast	10-49	3.9-19.2%		Fade
		Off	50-59	19.6-23.1%		Snap
		Random slow > fast	60-109	23.5-42.7%		Fade
		Off	110-119	43.1-46.7%		Snap
		Random pixel slow > fast	120-169	47.1-66.3%		Fade
		Off	170-255	66.7-100%		Snap
10	<b>Layer 2 Red</b>	Intensity 0-100%	0-255	0-100%	0	Fade
11	<b>Layer 2 Green</b>	Intensity 0-100%	0-255	0-100%	0	Fade
12	<b>Layer 2 Blue</b>	Intensity 0-100%	0-255	0-100%	0	Fade
13	<b>Layer 2 White</b>	Intensity 0-100%	0-255	0-100%	0	Fade
14	<b>Layer 2 FX selection</b>	FX Off	0-2	0-0.8%	0	Snap
		Sync strobe - circle mask	3-5	1.2-2.0%		
		Sync strobe - 4 dot mask	6-8	2.4-3.1%		
		Sync strobe - 1 dot mask	9-11	3.5-4.3%		
		Random strobe - all	12-14	4.7-5.5%		
		Random strobe - circle mask	15-17	5.9-6.7%		
		Random strobe - 4 dot mask	18-20	7.1-7.8%		
		Random strobe - 1 dot mask	21-23	8.2-9.0%		
		Lite in/out - all	24-26	9.4-10.2%		
		Lite in/out - circle mask	27-29	10.6-11.4%		
		Lite in/out - 4 dot mask	30-32	11.8-12.6%		
		Lite in/out - 1 dot mask	33-35	12.9-13.7%		
		Snake	36-38	14.1-14.9%		
		Raindrops	39-41	15.3-16.1%		
		Random pixel	42-44	16.5-17.3%		
		Random fake x 2	45-47	17.6-18.4%		
		Random fake x 4	48-50	18.8-19.6%		
Line	51-53	20.0-20.8%				
Double line	54-56	21.2-22.0%				
Corner to corner line	57-59	22.4-23.1%				

		Tilted double lines	60-62	23.5-24.3%		
		Tilted double lines in to out	63-65	24.7-25.5%		
		Center line running dot	66-68	25.9-26.7%		
		Middle line running dot	69-71	27.1-27.8%		
		Outer line running dot	72-74	28.2-29.0%		
		Corner to corner	75-77	29.4-30.2%		
		Arrow	78-80	30.6-31.4%		
		Wave	81-83	31.8-32.5%		
		Wheel	84-86	32.9-33.7%		
		Half wheel	87-89	34.1-34.9%		
		Circling dot	90-92	35.3-36.1%		
		Outer circle	93-95	36.5-37.3%		
		Inner circle	96-98	37.6-38.4%		
		Outer 4 dots	99-101	38.8-39.6%		
		Outer single dot	102-104	40.0-40.8%		
		Middle single dot	105-107	41.2-42.0%		
		Spinning 2x1 dots	108-110	42.4-43.1%		
		Asymmetrical 4 dots	111-113	43.5-44.3%		
		Symmetrical 4 dots	114-116	44.7-45.5%		
		Square	117-119	45.9-46.7%		
		Inside out	120-122	47.1-48.8%		
		Inside out 2	123-125	48.2-49.0%		
		Abstract 1	126-128	49.4-50.2%		
		Abstract 2	129-131	50.6-51.4%		
		Abstract 3	132-134	51.8-52.5%		
		Hash tag	135-137	52.9-53.7%		
		Flip flop	138-140	54.1-54.9%		
		Jumping slash	141-143	55.3-56.1%		
		Jumping 'L'	144-146	56.5-57.3%		
		Jumping pins	147-149	57.6-58.4%		
		Off - No Strobe or FX	150-255	58.8-100%		
15	Layer 2 FX crossfade time	Off	0-1	0-0.4%	0	Snap
		Crossfade fast > slow	2-127	0.8-49.8%		Fade
		Crossfade and tail slow > fast	128-255	50.2-100%		Fade
16	Layer 2 orientation	Off	0-4	0-1.6%	0	Snap
		Rotate 90°	5-9	2.0-3.5%		
		Rotate 180°	10-14	3.9-5.5%		
		Rotate 270°	15-19	5.9-7.5%		
		Horizontal flip	20-24	7.8-9.4%		
		Rotate 90° & vertical flip	25-29	9.8-11.4%		
		Rotate 180° & horizontal flip	30-34	11.8-13.3%		
		Rotate 270° & vertical flip	35-39	13.7-15.3%		
		Off	40-44	15.7-17.3%		
		Random rotate & flip	45-49	17.7-19.2%		
		Random position	50-54	19.6-21.2%		
		Fix 90° rotation & random position	55-59	21.6-23.1%		
		Fix 180° rotation & random position	60-64	23.5-25.1%		
		Fix 270° rotation & random position	65-69	25.5-27.1%		
		Off	70-74	27.5-29.0%		
		Bounce	75-79	29.4-31.0%		
		Bounce & rotate 90°	80-84	31.4-32.9%		
		Bounce & rotate 180°	85-89	33.3-34.9%		
		Bounce & rotate 270°	90-94	35.3-36.9%		
		Off	95-99	37.3-38.8%		
Rotate CCW at end	100-104	39.2-40.8%				

		Rotate CW at end	105-109	41.2-42.7%		
		Random rotate at end	110-114	43.1-44.7%		
		Off	115-134	45.1-52.5%		
		Rotate 90° **	135-139	52.9-54.5%		
		Rotate 180° **	140-144	54.9-56.5%		
		Rotate 270° **	145-149	56.9-58.4%		
		Horizontal flip **	150-154	58.8-60.4%		
		Rotate 90° & vertical flip **	155-159	60.8-62.4%		
		Rotate 180° & horizontal flip **	160-164	62.7-64.3%		
		Rotate 270° & vertical flip **	165-169	64.7-66.3%		
		Off	170-174	66.7-68.2%		
		Random Rotate & flip **	175-179	68.6-70.2%		
		Random position **	180-184	70.6-72.2%		
		Fix 90° rotation & random posn. **	185-189	72.5-74.1%		
		Fix 180° rotation & random posn. **	190-194	74.5-76.1%		
		Fix 270° rotation & random posn. **	195-199	76.5-78.0%		
		Off	200-204	78.4-80.0%		
		Bounce **	205-209	80.4-82.0%		
		Bounce & rotate 90° **	210-214	82.4-83.9%		
		Bounce & rotate 180° **	215-219	84.3-85.9%		
		Bounce & rotate 270° **	220-224	86.3-87.8%		
		Off	225-229	88.2-89.8%		
		Rotate CCW at end **	230-234	90.2-91.8%		
		Rotate CW at end **	235-239	92.2-93.7%		
		Random rotate at end **	240-244	94.1-95.7%		
		Off	245-255	96.1-100%		
<b>17</b>	<b>Layer 2 FX offset</b>	0-100%	0-255	0-100%	0	Fade
<b>18</b>	<b>Layer 2 FX length</b>	0-100%	0-255	0-100%	0	Fade
<b>19</b>	<b>Layer 2 FX color generator</b>	Off	0-9	0-3.5%	0	Snap
		Random all pixels RGBCMY	10-19	3.9-7.5%		Snap
		Random single pixel RGBCMY	20-29	7.8-11.4%		Snap
		Random all pixels bright colors	30-39	11.8-15.3%		Snap
		Random single pixel bright colors	40-49	15.7-19.2%		Snap
		Red / Blue	50-59	19.6-23.1%		Snap
		Red / Green	60-69	23.5-27.1%		Snap
		Blue / Green	70-79	27.5-31.0%		Snap
		Yellow / Magenta	80-89	31.4-34.9%		Snap
		Yellow / Cyan	90-99	35.3-38.8%		Snap
		Cyan / Magenta	100-109	39.2-42.7%		Snap
		Yellow / Blue	110-119	43.1-46.7%		Snap
		Green / Magenta	120-129	47.1-50.6%		Snap
		Red / Green / Blue	130-139	51.0-54.5%		Snap
		Red / Yellow / Blue	140-149	54.9-58.4%		Snap
		Red / Green / Blue / Yellow / Magenta / Cyan	150-159	58.8%-62.4%		Snap
		Red / Green / Blue - Horizontal line	160-169	62.7-66.3%		Snap
		Red / Green / Blue - Vertical line	170-179	66.7-70.2%		Snap
		No function	180-219	70.6-85.9%		Snap
		Color scroll, slow -> fast	220-229	86.3-89.8%		Fade
		Lite in	230-239	90.2-93.7%		Snap
		Lite out	240-249	94.1-97.6%		Snap
		Off	250-255	98.0-100%		Snap

Channel group C: Layer 3 RGBW strobe with FX (high priority, true color)							
20	Layer 3 master	Layer 3 = transparent	0-1	0-0.4%	0	Snap Fade	
21		Layer 3 intensity 0-100%	2-65535	0.8-100%			
22	Layer 3 flash duration	7-650 ms	0-255	0-100%	0	Fade	
23	Layer 3 flash rate (if FX are not active)	No flash	0-1	0-0.4%	0	Snap	
		<i>Single flash if Dimmer Flash = ON and value is changed on Ch 20</i>					
		Flash rate 0.289-16.67 Hz	2-250	0.8-98%		Fade	
		Hyperspeed	251-252	98.4-98.8%		Snap	
	Continuously on	253-255	99.2-100%	Snap			
	Layer 3 FX speed (if FX are active)	FX speed = stop	0-1	0-0.4%	Snap		
		FX speed = slow > fast	2-253	0.8-98.8%	Fade		
FX speed = stop		254-255	99.2-100%	Snap			
24	Layer 3 Flare effect	Off	0-9	0-3.5%	0	Snap	
		Slow > fast	10-49	3.9-19.2%		Fade	
		Off	50-59	19.6-23.1%		Snap	
		Random slow > fast	60-109	23.5-42.7%		Fade	
		Off	110-119	43.1-46.7%		Snap	
		Random pixel slow > fast	120-169	47.1-66.3%		Fade	
		Off	170-255	66.7-100%		Snap	
25	Layer 3 Red	Intensity 0-100%	0-255	0-100%	0	Fade	
26	Layer 3 Green	Intensity 0-100%	0-255	0-100%	0	Fade	
27	Layer 3 Blue	Intensity 0-100%	0-255	0-100%	0	Fade	
28	Layer 3 White	Intensity 0-100%	0-255	0-100%	0	Fade	
29	Layer 3 FX selection	FX Off	0-2	0-0.8%	0	Snap	
		Sync strobe - circle mask	3-5	1.2-2.0%			
		Sync strobe - 4 dot mask	6-8	2.4-3.1%			
		Sync strobe - 1 dot mask	9-11	3.5-4.3%			
		Random strobe - all	12-14	4.7-5.5%			
		Random strobe - circle mask	15-17	5.9-6.7%			
		Random strobe - 4 dot mask	18-20	7.1-7.8%			
		Random strobe - 1 dot mask	21-23	8.2-9.0%			
		Life in/out - all	24-26	9.4-10.2%			
		Life in/out - circle mask	27-29	10.6-11.4%			
		Life in/out - 4 dot mask	30-32	11.8-12.6%			
		Life in/out - 1 dot mask	33-35	12.9-13.7%			
		Snake	36-38	14.1-14.9%			
		Raindrops	39-41	15.3-16.1%			
		Random pixel	42-44	16.5-17.3%			
		Random fake x 2	45-47	17.6-18.4%			
		Random fake x 4	48-50	18.8-19.6%			
		Line	51-53	20.0-20.8%			
		Double line	54-56	21.2-22.0%			
		Corner to corner line	57-59	22.4-23.1%			
		Tilted double lines	60-62	23.5-24.3%			
		Tilted double lines in to out	63-65	24.7-25.5%			
		Center line running dot	66-68	25.9-26.7%			
		Middle line running dot	69-71	27.1-27.8%			
		Outer line running dot	72-74	28.2-29.0%			
		Corner to corner	75-77	29.4-30.2%			
		Arrow	78-80	30.6-31.4%			
Wave	81-83	31.8-32.5%					
Wheel	84-86	32.9-33.7%					
Half wheel	87-89	34.1-34.9%					
Circling dot	90-92	35.3-36.1%					

		Outer circle	93-95	36.5-37.3%		
		Inner circle	96-98	37.6-38.4%		
		Outer 4 dots	99-101	38.8-39.6%		
		Outer single dot	102-104	40.0-40.8%		
		Middle single dot	105-107	41.2-42.0%		
		Spinning 2x1 dots	108-110	42.4-43.1%		
		Asymmetrical 4 dots	111-113	43.5-44.3%		
		Symmetrical 4 dots	114-116	44.7-45.5%		
		Square	117-119	45.9-46.7%		
		Inside out	120-122	47.1-48.8%		
		Inside out 2	123-125	48.2-49.0%		
		Abstract 1	126-128	49.4-50.2%		
		Abstract 2	129-131	50.6-51.4%		
		Abstract 3	132-134	51.8-52.5%		
		Hash tag	135-137	52.9-53.7%		
		Flip flop	138-140	54.1-54.9%		
		Jumping slash	141-143	55.3-56.1%		
		Jumping 'L'	144-146	56.5-57.3%		
		Jumping pins	147-149	57.6-58.4%		
		Off - no strobe or FX	150-255	58.8-100%		
30	Layer 3 FX crossfade time	Off	0-1	0-0.4%	0	Snap
		Crossfade fast > slow	2-127	0.8-49.8%		Fade
		Crossfade and tail slow > fast	128-255	50.2-100%		Fade
31	Layer 3 orientation	Off	0-4	0-1.6%	0	Snap
		Rotate 90°	5-9	2.0-3.5%		
		Rotate 180°	10-14	3.9-5.5%		
		Rotate 270°	15-19	5.9-7.5%		
		Horizontal flip	20-24	7.8-9.4%		
		Rotate 90° & vertical flip	25-29	9.8-11.4%		
		Rotate 180° & horizontal flip	30-34	11.8-13.3%		
		Rotate 270° & vertical flip	35-39	13.7-15.3%		
		Off	40-44	15.7-17.3%		
		Random rotate & flip	45-49	17.7-19.2%		
		Random position	50-54	19.6-21.2%		
		Fix 90° rotation & random position	55-59	21.6-23.1%		
		Fix 180° rotation & random position	60-64	23.5-25.1%		
		Fix 270° rotation & random position	65-69	25.5-27.1%		
		Off	70-74	27.5-29.0%		
		Bounce	75-79	29.4-31.0%		
		Bounce & rotate 90°	80-84	31.4-32.9%		
		Bounce & rotate 180°	85-89	33.3-34.9%		
		Bounce & rotate 270°	90-94	35.3-36.9%		
		Off	95-99	37.3-38.8%		
		Rotate CCW at end	100-104	39.2-40.8%		
		Rotate CW at end	105-109	41.2-42.7%		
		Random rotate at end	110-114	43.1-44.7%		
		Off	115-134	45.1-52.5%		
		Rotate 90° **	135-139	52.9-54.5%		
		Rotate 180° **	140-144	54.9-56.5%		
		Rotate 270° **	145-149	56.9-58.4%		
		Horizontal flip **	150-154	58.8-60.4%		
		Rotate 90° & vertical flip **	155-159	60.8-62.4%		
		Rotate 180° & horizontal flip **	160-164	62.7-64.3%		
		Rotate 270° & vertical flip **	165-169	64.7-66.3%		
Off	170-174	66.7-68.2%				

		Random Rotate & flip **	175-179	68.6-70.2%		
		Random position **	180-184	70.6-72.2%		
		Fix 90° rotation & random posn. **	185-189	72.5-74.1%		
		Fix 180° rotation & random posn. **	190-194	74.5-76.1%		
		Fix 270° rotation & random posn. **	195-199	76.5-78.0%		
		Off	200-204	78.4-80.0%		
		Bounce **	205-209	80.4-82.0%		
		Bounce & rotate 90° **	210-214	82.4-83.9%		
		Bounce & rotate 180° **	215-219	84.3-85.9%		
		Bounce & rotate 270° **	220-224	86.3-87.8%		
		Off	225-229	88.2-89.8%		
		Rotate CCW at end **	230-234	90.2-91.8%		
		Rotate CW at end **	235-239	92.2-93.7%		
		Random rotate at end **	240-244	94.1-95.7%		
		Off	245-255	96.1-100%		
<b>32</b>	<b>Layer 3 FX offset</b>	0-100%	0-255	0-100%	0	Fade
<b>33</b>	<b>Layer 3 FX length</b>	0-100%	0-255	0-100%	0	Fade
<b>34</b>	<b>Layer 3 FX color generator</b>	Off	0-9	0-3.5%	0	Snap
		Random all pixels RGBCMY	10-19	3.9-7.5%		Snap
		Random single pixel RGBCMY	20-29	7.8-11.4%		Snap
		Random all pixels bright colors	30-39	11.8-15.3%		Snap
		Random single pixel bright colors	40-49	15.7-19.2%		Snap
		Red / Blue	50-59	19.6-23.1%		Snap
		Red / Green	60-69	23.5-27.1%		Snap
		Blue / Green	70-79	27.5-31.0%		Snap
		Yellow / Magenta	80-89	31.4-34.9%		Snap
		Yellow / Cyan	90-99	35.3-38.8%		Snap
		Cyan / Magenta	100-109	39.2-42.7%		Snap
		Yellow / Blue	110-119	43.1-46.7%		Snap
		Green / Magenta	120-129	47.1-50.6%		Snap
		Red / Green / Blue	130-139	51.0-54.5%		Snap
		Red / Yellow / Blue	140-149	54.9-58.4%		Snap
		Red / Green / Blue / Yellow / Magenta / Cyan	150-159	58.8%-62.4%		Snap
		Red / Green / Blue - Horizontal line	160-169	62.7-66.3%		Snap
		Red / Green / Blue - Vertical line	170-179	66.7-70.2%		Snap
		No function	180-219	70.6-85.9%		Snap
		Color scroll, slow -> fast	220-229	86.3-89.8%		Fade
		Lite in	230-239	90.2-93.7%		Snap
Lite out	240-249	94.1-97.6%	Snap			
Off	250-255	98.0-100%	Snap			

Control / Settings						
35	Control / Settings	Idle	0-11	0-4.3%	0	Snap
		No function	12-38	4.7-14.9%		
		<b>Dimmer flash Off*</b>	39-41	15.3-16.1%		
		Dimmer flash On*	42-44	16.5-17.3%		
		No function	45-47	17.6-18.4%		
		<b>Dimming curve Soft*</b>	48-50	18.8-19.6%		
		Dimming curve Linear*	51-53	20.0-20.8%		
		No function	54-68	21.2-26.7%		
		<b>Fan mode regulated*</b>	69-71	27.1-27.8%		
		Fan mode high*	72-74	28.2-29.0%		
		Fan mode medium*	75-77	29.4-30.2%		
		Fan mode low*	78-80	30.6-31.4%		
		No function	81-83	31.8-32.5%		
		Display On*	84-86	32.9-33.7%		
		Display Off*	87-89	34.1-34.9%		
		<b>Display Auto*</b>	90-92	35.3-36.1%		
		<b>Display invert Off*</b>	93-95	36.5-37.3%		
		Display invert On*	96-98	37.6-38.4%		
		No DMX = Capture scene*	99-101	38.8-39.6%		
		No DMX = Stand-alone*	102-104	40.0-40.8%		
		<b>No DMX = Blackout*</b>	105-107	41.2-42.0%		
		No DMX = Hold*	108-110	42.4-43.1%		
		Test pattern On*	111-113	43.5-44.3%		
		<b>Test pattern Off*</b>	114-116	44.7-45.5%		
		<b>Rotation Off*</b>	117-119	45.9-46.7%		
		Rotate 90° *	120-122	47.1-47.8%		
		Rotate 180° *	123-125	48.2-49.0%		
		Rotate 270° *	126-128	49.4-50.2%		
		<b>Pixel mirror Off*</b>	129-131	50.6-51.4%		
		Pixel mirror On*	132-134	51.8-52.5%		
		<b>White output limitation Off*</b>	135-137	52.9-53.7%		
		White output limitation 80%*	138-140	54.1-54.9%		
		White output limitation 60%*	141-143	55.3-56.1%		
		White output limitation 40%*	144-146	56.5-57.3%		
		White output limitation 20%*	147-149	57.6-58.4%		
		White output limitation 10%*	150-152	58.8-59.6%		
		No function	153-158	60.0-62.0%		
		<b>RGB output limitation Off%*</b>	159-161	62.4-63.1%		
		RGB output limitation 80%*	162-164	63.5-64.3%		
		RGB output limitation 60%*	165-167	64.7-65.5%		
		RGB output limitation 40%*	168-170	65.9-66.7%		
		RGB output limitation 20%*	171-173	67.1-67.8%		
		RGB output limitation 10%*	174-176	68.2-69.0%		
		No function	177-251	69.4-98.4%		
		Reboot fixture*	252-255	98.8-100%		



## DMX Mode 6: RGBW 25-pixel, 8-bit

### 102 DMX Channels

Channel	Command	DMX range	Percent	Default DMX	Fade	
<b>RGBW 25-pixel 8-bit</b>						
1	Pixel 1 RGBW	Red intensity 0-100%	0-255	0-100%	0	Fade
2		Green intensity 0-100%	0-255	0-100%	0	Fade
3		Blue intensity 0-100%	0-255	0-100%	0	Fade
4		White intensity 0-100%	0-255	0-100%	0	Fade
5	Pixel 2 RGBW	Red intensity 0-100%	0-255	0-100%	0	Fade
6		Green intensity 0-100%	0-255	0-100%	0	Fade
7		Blue intensity 0-100%	0-255	0-100%	0	Fade
8		White intensity 0-100%	0-255	0-100%	0	Fade
9	Pixel 3 RGBW	Red intensity 0-100%	0-255	0-100%	0	Fade
10		Green intensity 0-100%	0-255	0-100%	0	Fade
11		Blue intensity 0-100%	0-255	0-100%	0	Fade
12		White intensity 0-100%	0-255	0-100%	0	Fade
13	Pixel 4 RGBW	Red intensity 0-100%	0-255	0-100%	0	Fade
14		Green intensity 0-100%	0-255	0-100%	0	Fade
15		Blue intensity 0-100%	0-255	0-100%	0	Fade
16		White intensity 0-100%	0-255	0-100%	0	Fade
17	Pixel 5 RGBW	Red intensity 0-100%	0-255	0-100%	0	Fade
18		Green intensity 0-100%	0-255	0-100%	0	Fade
19		Blue intensity 0-100%	0-255	0-100%	0	Fade
20		White intensity 0-100%	0-255	0-100%	0	Fade
21	Pixel 6 RGBW	Red intensity 0-100%	0-255	0-100%	0	Fade
22		Green intensity 0-100%	0-255	0-100%	0	Fade
23		Blue intensity 0-100%	0-255	0-100%	0	Fade
24		White intensity 0-100%	0-255	0-100%	0	Fade
25	Pixel 7 RGBW	Red intensity 0-100%	0-255	0-100%	0	Fade
26		Green intensity 0-100%	0-255	0-100%	0	Fade
27		Blue intensity 0-100%	0-255	0-100%	0	Fade
28		White intensity 0-100%	0-255	0-100%	0	Fade
29	Pixel 8 RGBW	Red intensity 0-100%	0-255	0-100%	0	Fade
30		Green intensity 0-100%	0-255	0-100%	0	Fade
31		Blue intensity 0-100%	0-255	0-100%	0	Fade
32		White intensity 0-100%	0-255	0-100%	0	Fade
33	Pixel 9 RGBW	Red intensity 0-100%	0-255	0-100%	0	Fade
34		Green intensity 0-100%	0-255	0-100%	0	Fade
35		Blue intensity 0-100%	0-255	0-100%	0	Fade
36		White intensity 0-100%	0-255	0-100%	0	Fade
37	Pixel 10 RGBW	Red intensity 0-100%	0-255	0-100%	0	Fade
38		Green intensity 0-100%	0-255	0-100%	0	Fade
39		Blue intensity 0-100%	0-255	0-100%	0	Fade
40		White intensity 0-100%	0-255	0-100%	0	Fade
41	Pixel 11 RGBW	Red intensity 0-100%	0-255	0-100%	0	Fade
42		Green intensity 0-100%	0-255	0-100%	0	Fade
43		Blue intensity 0-100%	0-255	0-100%	0	Fade
44		White intensity 0-100%	0-255	0-100%	0	Fade
45	Pixel 12 RGBW	Red intensity 0-100%	0-255	0-100%	0	Fade
46		Green intensity 0-100%	0-255	0-100%	0	Fade
47		Blue intensity 0-100%	0-255	0-100%	0	Fade
48		White intensity 0-100%	0-255	0-100%	0	Fade

49	Pixel 13 RGBW	Red intensity 0-100%	0-255	0-100%	0	Fade
50		Green intensity 0-100%	0-255	0-100%	0	Fade
51		Blue intensity 0-100%	0-255	0-100%	0	Fade
52		White intensity 0-100%	0-255	0-100%	0	Fade
53	Pixel 14 RGBW	Red intensity 0-100%	0-255	0-100%	0	Fade
54		Green intensity 0-100%	0-255	0-100%	0	Fade
55		Blue intensity 0-100%	0-255	0-100%	0	Fade
56		White intensity 0-100%	0-255	0-100%	0	Fade
57	Pixel 15 RGBW	Red intensity 0-100%	0-255	0-100%	0	Fade
58		Green intensity 0-100%	0-255	0-100%	0	Fade
59		Blue intensity 0-100%	0-255	0-100%	0	Fade
60		White intensity 0-100%	0-255	0-100%	0	Fade
61	Pixel 16 RGBW	Red intensity 0-100%	0-255	0-100%	0	Fade
62		Green intensity 0-100%	0-255	0-100%	0	Fade
63		Blue intensity 0-100%	0-255	0-100%	0	Fade
64		White intensity 0-100%	0-255	0-100%	0	Fade
65	Pixel 17 RGBW	Red intensity 0-100%	0-255	0-100%	0	Fade
66		Green intensity 0-100%	0-255	0-100%	0	Fade
67		Blue intensity 0-100%	0-255	0-100%	0	Fade
68		White intensity 0-100%	0-255	0-100%	0	Fade
69	Pixel 18 RGBW	Red intensity 0-100%	0-255	0-100%	0	Fade
70		Green intensity 0-100%	0-255	0-100%	0	Fade
71		Blue intensity 0-100%	0-255	0-100%	0	Fade
72		White intensity 0-100%	0-255	0-100%	0	Fade
73	Pixel 19 RGBW	Red intensity 0-100%	0-255	0-100%	0	Fade
74		Green intensity 0-100%	0-255	0-100%	0	Fade
75		Blue intensity 0-100%	0-255	0-100%	0	Fade
76		White intensity 0-100%	0-255	0-100%	0	Fade
77	Pixel 20 RGBW	Red intensity 0-100%	0-255	0-100%	0	Fade
78		Green intensity 0-100%	0-255	0-100%	0	Fade
79		Blue intensity 0-100%	0-255	0-100%	0	Fade
80		White intensity 0-100%	0-255	0-100%	0	Fade
81	Pixel 21 RGBW	Red intensity 0-100%	0-255	0-100%	0	Fade
82		Green intensity 0-100%	0-255	0-100%	0	Fade
83		Blue intensity 0-100%	0-255	0-100%	0	Fade
84		White intensity 0-100%	0-255	0-100%	0	Fade
85	Pixel 22 RGBW	Red intensity 0-100%	0-255	0-100%	0	Fade
86		Green intensity 0-100%	0-255	0-100%	0	Fade
87		Blue intensity 0-100%	0-255	0-100%	0	Fade
88		White intensity 0-100%	0-255	0-100%	0	Fade
89	Pixel 23 RGBW	Red intensity 0-100%	0-255	0-100%	0	Fade
90		Green intensity 0-100%	0-255	0-100%	0	Fade
91		Blue intensity 0-100%	0-255	0-100%	0	Fade
92		White intensity 0-100%	0-255	0-100%	0	Fade
93	Pixel 24 RGBW	Red intensity 0-100%	0-255	0-100%	0	Fade
94		Green intensity 0-100%	0-255	0-100%	0	Fade
95		Blue intensity 0-100%	0-255	0-100%	0	Fade
96		White intensity 0-100%	0-255	0-100%	0	Fade
97	Pixel 25 RGBW	Red intensity 0-100%	0-255	0-100%	0	Fade
98		Green intensity 0-100%	0-255	0-100%	0	Fade
99		Blue intensity 0-100%	0-255	0-100%	0	Fade
100		White intensity 0-100%	0-255	0-100%	0	Fade
101	Shutter, all pixels	Shutter closed	0-4	0-1.6%	255	Snap
		Sync ramp up slow > fast	5-39	2.0-15.3%		Fade
		Sync ramp down slow > fast	40-74	15.7-29.0%		Fade
		Sync ramp up-down slow > fast	75-109	29.4-42.7%		Fade
		Sync double flash slow > fast	110-144	43.1-56.5%		Fade
		Pixel flare effect slow > fast	145-179	56.9-70.2%		Fade

		Random strobe slow > fast	180-214	70.6-83.9%		Fade
		Sync strobe 0.289 > 16.67 Hz	215-249	84.3-97.6%		Fade
		Hyperspeed	250-252	98.0-98.8%		Snap
		Open	253-255	99.2-100%		Snap
<b>Control / Settings</b>						
102	Control / Settings	Idle	0-11	0-4.3%	0	Snap
		No function	12-38	4.7-14.9%		
		<b>Dimmer flash Off*</b>	39-41	15.3-16.1%		
		Dimmer flash On*	42-44	16.5-17.3%		
		No function	45-47	17.6-18.4%		
		<b>Dimming curve Soft*</b>	48-50	18.8-19.6%		
		Dimming curve Linear*	51-53	20.0-20.8%		
		No function	54-56	21.2-22.0%		
		<b>Extra Shutter RGBW*</b>	57-59	22.4-23.1%		
		Extra Shutter RGB only*	60-62	23.5-24.3%		
		Extra Shutter White only*	63-65	24.7-25.5%		
		No function	66-68	25.9-26.7%		
		<b>Fan mode regulated*</b>	69-71	27.1-27.8%		
		Fan mode high*	72-74	28.2-29.0%		
		Fan mode medium*	75-77	29.4-30.2%		
		Fan mode low*	78-80	30.6-31.4%		
		No function	81-83	31.8-32.5%		
		Display On*	84-86	32.9-33.7%		
		Display Off*	87-89	34.1-34.9%		
		<b>Display Auto*</b>	90-92	35.3-36.1%		
		<b>Display invert Off*</b>	93-95	36.5-37.3%		
		Display invert On*	96-98	37.6-38.4%		
		No DMX = Capture scene*	99-101	38.8-39.6%		
		No DMX = Stand-alone*	102-104	40.0-40.8%		
		<b>No DMX = Blackout*</b>	105-107	41.2-42.0%		
		No DMX = Hold*	108-110	42.4-43.1%		
		Test pattern On*	111-113	43.5-44.3%		
		<b>Test pattern Off*</b>	114-116	44.7-45.5%		
		<b>Rotation Off*</b>	117-119	45.9-46.7%		
		Rotate 90° *	120-122	47.1-47.8%		
		Rotate 180° *	123-125	48.2-49.0%		
		Rotate 270° *	126-128	49.4-50.2%		
		<b>Pixel mirror Off*</b>	129-131	50.6-51.4%		
		Pixel mirror On*	132-134	51.8-52.5%		
		<b>White output limitation Off*</b>	135-137	52.9-53.7%		
		White output limitation 80%*	138-140	54.1-54.9%		
		White output limitation 60%*	141-143	55.3-56.1%		
		White output limitation 40%*	144-146	56.5-57.3%		
		White output limitation 20%*	147-149	57.6-58.4%		
		White output limitation 10%*	150-152	55.8-59.6%		
No function	153-158	60.0-62.0%				
<b>RGB output limitation Off%*</b>	159-161	62.4-63.1%				
RGB output limitation 80%*	162-164	63.5-64.3%				
RGB output limitation 60%*	165-167	64.7-65.5%				
RGB output limitation 40%*	168-170	65.9-66.7%				
RGB output limitation 20%*	171-173	67.1-67.8%				
RGB output limitation 10%*	174-176	68.2-69.0%				
No function	177-251	69.4-98.4%				
Reboot fixture*	252-255	98.8-100%				

## DMX Mode 7: RGBW 25-pixel, 16-bit

### 202 DMX Channels

Channel	Command	DMX range	Percent	Default DMX	Fade	
<b>RGBW 25-pixel 16-bit</b>						
1	<b>Pixel 1 RGBW (16-bit)</b>	Red intensity coarse	0-65535	0-100%	0	Fade
2		Red intensity fine				
3		Green intensity coarse	0-65535	0-100%	0	Fade
4		Green intensity fine				
5		Blue intensity coarse	0-65535	0-100%	0	Fade
6		Blue intensity fine				
7		White intensity coarse	0-65535	0-100%	0	Fade
8		White intensity fine				
9	<b>Pixel 2 RGBW (16-bit)</b>	Red intensity coarse	0-65535	0-100%	0	Fade
10		Red intensity fine				
11		Green intensity coarse	0-65535	0-100%	0	Fade
12		Green intensity fine				
13		Blue intensity coarse	0-65535	0-100%	0	Fade
14		Blue intensity fine				
15		White intensity coarse	0-65535	0-100%	0	Fade
16		White intensity fine				
17	<b>Pixel 3 RGBW (16-bit)</b>	Red intensity coarse	0-65535	0-100%	0	Fade
18		Red intensity fine				
19		Green intensity coarse	0-65535	0-100%	0	Fade
20		Green intensity fine				
21		Blue intensity coarse	0-65535	0-100%	0	Fade
22		Blue intensity fine				
23		White intensity coarse	0-65535	0-100%	0	Fade
24		White intensity fine				
25	<b>Pixel 4 RGBW (16-bit)</b>	Red intensity coarse	0-65535	0-100%	0	Fade
26		Red intensity fine				
27		Green intensity coarse	0-65535	0-100%	0	Fade
28		Green intensity fine				
29		Blue intensity coarse	0-65535	0-100%	0	Fade
30		Blue intensity fine				
31		White intensity coarse	0-65535	0-100%	0	Fade
32		White intensity fine				
33	<b>Pixel 5 RGBW (16-bit)</b>	Red intensity coarse	0-65535	0-100%	0	Fade
34		Red intensity fine				
35		Green intensity coarse	0-65535	0-100%	0	Fade
36		Green intensity fine				
37		Blue intensity coarse	0-65535	0-100%	0	Fade
38		Blue intensity fine				
39		White intensity coarse	0-65535	0-100%	0	Fade
40		White intensity fine				
41	<b>Pixel 6 RGBW (16-bit)</b>	Red intensity coarse	0-65535	0-100%	0	Fade
42		Red intensity fine				
43		Green intensity coarse	0-65535	0-100%	0	Fade
44		Green intensity fine				
45		Blue intensity coarse	0-65535	0-100%	0	Fade
46		Blue intensity fine				
47		White intensity coarse	0-65535	0-100%	0	Fade
48		White intensity fine				

49	<b>Pixel 7 RGBW (16-bit)</b>	Red intensity coarse	0-65535	0-100%	0	Fade
50		Red intensity fine				
51		Green intensity coarse	0-65535	0-100%	0	Fade
52		Green intensity fine				
53		Blue intensity coarse	0-65535	0-100%	0	Fade
54		Blue intensity fine				
55		White intensity coarse	0-65535	0-100%	0	Fade
56		White intensity fine				
57	<b>Pixel 8 RGBW (16-bit)</b>	Red intensity coarse	0-65535	0-100%	0	Fade
58		Red intensity fine				
59		Green intensity coarse	0-65535	0-100%	0	Fade
60		Green intensity fine				
61		Blue intensity coarse	0-65535	0-100%	0	Fade
62		Blue intensity fine				
63		White intensity coarse	0-65535	0-100%	0	Fade
64		White intensity fine				
65	<b>Pixel 9 RGBW (16-bit)</b>	Red intensity coarse	0-65535	0-100%	0	Fade
66		Red intensity fine				
67		Green intensity coarse	0-65535	0-100%	0	Fade
68		Green intensity fine				
69		Blue intensity coarse	0-65535	0-100%	0	Fade
70		Blue intensity fine				
71		White intensity coarse	0-65535	0-100%	0	Fade
72		White intensity fine				
73	<b>Pixel 10 RGBW (16-bit)</b>	Red intensity coarse	0-65535	0-100%	0	Fade
74		Red intensity fine				
75		Green intensity coarse	0-65535	0-100%	0	Fade
76		Green intensity fine				
77		Blue intensity coarse	0-65535	0-100%	0	Fade
78		Blue intensity fine				
79		White intensity coarse	0-65535	0-100%	0	Fade
80		White intensity fine				
81	<b>Pixel 11 RGBW (16-bit)</b>	Red intensity coarse	0-65535	0-100%	0	Fade
82		Red intensity fine				
83		Green intensity coarse	0-65535	0-100%	0	Fade
84		Green intensity fine				
85		Blue intensity coarse	0-65535	0-100%	0	Fade
86		Blue intensity fine				
87		White intensity coarse	0-65535	0-100%	0	Fade
88		White intensity fine				
89	<b>Pixel 12 RGBW (16-bit)</b>	Red intensity coarse	0-65535	0-100%	0	Fade
90		Red intensity fine				
91		Green intensity coarse	0-65535	0-100%	0	Fade
92		Green intensity fine				
93		Blue intensity coarse	0-65535	0-100%	0	Fade
94		Blue intensity fine				
95		White intensity coarse	0-65535	0-100%	0	Fade
96		White intensity fine				
97	<b>Pixel 13 RGBW (16-bit)</b>	Red intensity coarse	0-65535	0-100%	0	Fade
98		Red intensity fine				
99		Green intensity coarse	0-65535	0-100%	0	Fade
100		Green intensity fine				
101		Blue intensity coarse	0-65535	0-100%	0	Fade
102		Blue intensity fine				
103		White intensity coarse	0-65535	0-100%	0	Fade
104		White intensity fine				

105	<b>Pixel 14 RGBW (16-bit)</b>	Red intensity coarse	0-65535	0-100%	0	Fade
106		Red intensity fine				
107		Green intensity coarse	0-65535	0-100%	0	Fade
108		Green intensity fine				
109		Blue intensity coarse	0-65535	0-100%	0	Fade
110		Blue intensity fine				
111		White intensity coarse	0-65535	0-100%	0	Fade
112		White intensity fine				
113	<b>Pixel 15 RGBW (16-bit)</b>	Red intensity coarse	0-65535	0-100%	0	Fade
114		Red intensity fine				
115		Green intensity coarse	0-65535	0-100%	0	Fade
116		Green intensity fine				
117		Blue intensity coarse	0-65535	0-100%	0	Fade
118		Blue intensity fine				
119		White intensity coarse	0-65535	0-100%	0	Fade
120		White intensity fine				
121	<b>Pixel 16 RGBW (16-bit)</b>	Red intensity coarse	0-65535	0-100%	0	Fade
122		Red intensity fine				
123		Green intensity coarse	0-65535	0-100%	0	Fade
124		Green intensity fine				
125		Blue intensity coarse	0-65535	0-100%	0	Fade
126		Blue intensity fine				
127		White intensity coarse	0-65535	0-100%	0	Fade
128		White intensity fine				
129	<b>Pixel 17 RGBW (16-bit)</b>	Red intensity coarse	0-65535	0-100%	0	Fade
130		Red intensity fine				
131		Green intensity coarse	0-65535	0-100%	0	Fade
132		Green intensity fine				
133		Blue intensity coarse	0-65535	0-100%	0	Fade
134		Blue intensity fine				
135		White intensity coarse	0-65535	0-100%	0	Fade
136		White intensity fine				
137	<b>Pixel 18 RGBW (16-bit)</b>	Red intensity coarse	0-65535	0-100%	0	Fade
138		Red intensity fine				
139		Green intensity coarse	0-65535	0-100%	0	Fade
140		Green intensity fine				
141		Blue intensity coarse	0-65535	0-100%	0	Fade
142		Blue intensity fine				
143		White intensity coarse	0-65535	0-100%	0	Fade
144		White intensity fine				
145	<b>Pixel 19 RGBW (16-bit)</b>	Red intensity coarse	0-65535	0-100%	0	Fade
146		Red intensity fine				
147		Green intensity coarse	0-65535	0-100%	0	Fade
148		Green intensity fine				
149		Blue intensity coarse	0-65535	0-100%	0	Fade
150		Blue intensity fine				
151		White intensity coarse	0-65535	0-100%	0	Fade
152		White intensity fine				
153	<b>Pixel 20 RGBW (16-bit)</b>	Red intensity coarse	0-65535	0-100%	0	Fade
154		Red intensity fine				
155		Green intensity coarse	0-65535	0-100%	0	Fade
156		Green intensity fine				
157		Blue intensity coarse	0-65535	0-100%	0	Fade
158		Blue intensity fine				
159		White intensity coarse	0-65535	0-100%	0	Fade
160		White intensity fine				

161	<b>Pixel 21 RGBW (16-bit)</b>	Red intensity coarse	0-65535	0-100%	0	Fade
162		Red intensity fine				
163		Green intensity coarse	0-65535	0-100%	0	Fade
164		Green intensity fine				
165		Blue intensity coarse	0-65535	0-100%	0	Fade
166		Blue intensity fine				
167		White intensity coarse	0-65535	0-100%	0	Fade
168		White intensity fine				
169	<b>Pixel 22 RGBW (16-bit)</b>	Red intensity coarse	0-65535	0-100%	0	Fade
170		Red intensity fine				
171		Green intensity coarse	0-65535	0-100%	0	Fade
172		Green intensity fine				
173		Blue intensity coarse	0-65535	0-100%	0	Fade
174		Blue intensity fine				
175		White intensity coarse	0-65535	0-100%	0	Fade
176		White intensity fine				
177	<b>Pixel 23 RGBW (16-bit)</b>	Red intensity coarse	0-65535	0-100%	0	Fade
178		Red intensity fine				
179		Green intensity coarse	0-65535	0-100%	0	Fade
180		Green intensity fine				
181		Blue intensity coarse	0-65535	0-100%	0	Fade
182		Blue intensity fine				
183		White intensity coarse	0-65535	0-100%	0	Fade
184		White intensity fine				
185	<b>Pixel 24 RGBW (16-bit)</b>	Red intensity coarse	0-65535	0-100%	0	Fade
186		Red intensity fine				
187		Green intensity coarse	0-65535	0-100%	0	Fade
188		Green intensity fine				
189		Blue intensity coarse	0-65535	0-100%	0	Fade
190		Blue intensity fine				
191		White intensity coarse	0-65535	0-100%	0	Fade
192		White intensity fine				
193	<b>Pixel 25 RGBW (16-bit)</b>	Red intensity coarse	0-65535	0-100%	0	Fade
194		Red intensity fine				
195		Green intensity coarse	0-65535	0-100%	0	Fade
196		Green intensity fine				
197		Blue intensity coarse	0-65535	0-100%	0	Fade
198		Blue intensity fine				
199		White intensity coarse	0-65535	0-100%	0	Fade
200		White intensity fine				
201	<b>Shutter, all pixels</b>	Shutter closed	0-4	0-1.6%	255	Snap
		Sync ramp up slow > fast	5-39	2.0-15.3%		Fade
		Sync ramp down slow > fast	40-74	15.7-29.0%		Fade
		Sync ramp up-down slow > fast	75-109	29.4-42.7%		Fade
		Sync double flash slow > fast	110-144	43.1-56.5%		Fade
		Pixel flare effect slow > fast	145-179	56.9-70.2%		Fade
		Random strobe slow > fast	180-214	70.6-83.9%		Fade
		Sync strobe 0.289 > 16.67 Hz	215-249	84.3-97.6%		Fade
		Hyperspeed	250-252	98.0-98.8%		Snap
		Open	253-255	99.2-100%		Snap

Control / Settings						
202	Control / Settings	Idle	0-11	0-4.3%	0	Snap
		No function	12-38	4.7-14.9%		
		<b>Dimmer flash Off*</b>	39-41	15.3-16.1%		
		Dimmer flash On*	42-44	16.5-17.3%		
		No function	45-47	17.6-18.4%		
		<b>Dimming curve Soft*</b>	48-50	18.8-19.6%		
		Dimming curve Linear*	51-53	20.0-20.8%		
		No function	54-56	21.2-22.0%		
		<b>Extra Shutter RGBW*</b>	57-59	22.4-23.1%		
		Extra Shutter RGB only*	60-62	23.5-24.3%		
		Extra Shutter White only*	63-65	24.7-25.5%		
		No function	66-68	25.9-26.7%		
		<b>Fan mode regulated*</b>	69-71	27.1-27.8%		
		Fan mode high*	72-74	28.2-29.0%		
		Fan mode medium*	75-77	29.4-30.2%		
		Fan mode low*	78-80	30.6-31.4%		
		No function	81-83	31.8-32.5%		
		Display On*	84-86	32.9-33.7%		
		Display Off*	87-89	34.1-34.9%		
		<b>Display Auto*</b>	90-92	35.3-36.1%		
		<b>Display invert Off*</b>	93-95	36.5-37.3%		
		Display invert On*	96-98	37.6-38.4%		
		No DMX = Capture scene*	99-101	38.8-39.6%		
		No DMX = Stand-alone*	102-104	40.0-40.8%		
		<b>No DMX = Blackout*</b>	105-107	41.2-42.0%		
		No DMX = Hold*	108-110	42.4-43.1%		
		Test pattern On*	111-113	43.5-44.3%		
		<b>Test pattern Off*</b>	114-116	44.7-45.5%		
		<b>Rotation Off*</b>	117-119	45.9-46.7%		
		Rotate 90° *	120-122	47.1-47.8%		
		Rotate 180° *	123-125	48.2-49.0%		
		Rotate 270° *	126-128	49.4-50.2%		
		<b>Pixel mirror Off*</b>	129-131	50.6-51.4%		
		Pixel mirror On*	132-134	51.8-52.5%		
		<b>White output limitation Off*</b>	135-137	52.9-53.7%		
		White output limitation 80%*	138-140	54.1-54.9%		
		White output limitation 60%*	141-143	55.3-56.1%		
		White output limitation 40%*	144-146	56.5-57.3%		
		White output limitation 20%*	147-149	57.6-58.4%		
		White output limitation 10%*	150-152	58.8-59.6%		
		No function	153-158	60.0-62.0%		
		<b>RGB output limitation Off%*</b>	159-161	62.4-63.1%		
		RGB output limitation 80%*	162-164	63.5-64.3%		
RGB output limitation 60%*	165-167	64.7-65.5%				
RGB output limitation 40%*	168-170	65.9-66.7%				
RGB output limitation 20%*	171-173	67.1-67.8%				
RGB output limitation 10%*	174-176	68.2-69.0%				
No function	177-251	69.4-98.4%				
Reboot fixture*	252-255	98.8-100%				





# Quick Start and Safety Manual

# KNV



KNV  
CUBE



KNV  
ARC

Software Version 14



GLP® KNV Cube and Arc Quick Start and Safety Manual – Revision A

This manual covers fixture software version 14

---

© 2018 German Light Products GmbH. All rights reserved.

The marks 'GLP' and 'German Light Products' are trademarks registered as the property of German Light Products GmbH in Germany, in the United States of America and in other countries.

The information contained in this document is subject to change without notice. German Light Products GmbH and all affiliated companies disclaim liability for any injury, damage, direct or indirect loss, consequential or economic loss or any other loss occasioned by the use of, inability to use or reliance on the information contained in this document.

Manufacturer head office:

German Light Products GmbH (GLP), Industriestrasse 2, 76307 Karlsbad, Germany

Tel (Germany): +49 7248 92719 - 0

Service & Support EMEA:

GLP, Industriestrasse 2, 76307 Karlsbad, Germany

Tel. (Germany): +49 7248 9271955

Email: [support@glp.de](mailto:support@glp.de)

[www.glp.de](http://www.glp.de)

Service & Support USA:

GLP USA, 1145 Arroyo St., Ste. A, 91340 San Fernando, California

Tel (USA): +1 818 767 8899

Support (US): [info@germanlightproducts.com](mailto:info@germanlightproducts.com)

[www.germanlightproducts.com](http://www.germanlightproducts.com)

## Table of Contents

1. Safety .....	5
Key to symbols .....	5
General safety information .....	5
Electrical safety .....	6
Fire safety and protection from burns .....	7
Eye safety .....	8
Strobe safety .....	9
Installation safety and protection from personal injury .....	9
2. Avoiding damage to the fixture .....	11
General precautions .....	11
Avoiding damage from light sources .....	11
IP rating .....	12
Avoiding damage from water and humidity .....	12
Avoiding damage from dust and airborne particles .....	13
Transportation and storage .....	13
3. KNV Cube overview .....	14
4. KNV Arc overview .....	15
5. Features .....	16
Fixture control .....	16
6. Installation .....	17
Permitted mounting options .....	17
Installation hardware .....	18
Mechanical connectors .....	19
Fastening fixtures to each other .....	19
Using KNV connector plates .....	20
Standing a Cube upright on a level surface .....	22
Securing fixtures with a safety cable .....	23
Using KNV Installation Brackets .....	24
Suspending a single fixture .....	25
Installing an array of multiple fixtures .....	26
Installing a curved or circular array .....	27
Installing a creative array .....	30
7. AC mains power .....	31
Included items .....	31
Connecting to power .....	31
Installing power connectors .....	31
Connecting multiple fixtures to power in a chain .....	32
8. Connecting to control data .....	33
9. Starting and stopping operation .....	34

Transportation and storage .....	34
10. Cleaning and maintenance .....	35
Cleaning.....	35
GLP Service and Support.....	35
11. Technical specifications.....	36
12. Dimensions.....	39

## 1. Safety

### Key to symbols

The following symbols are used in this Guide:



**Warning!** Safety hazard.  
Risk of severe injury or death.



**Warning!** Hazardous voltage.  
Risk of lethal or severe electric shock.



**Warning!** See user manual for important safety information.



**Warning!** Fire hazard.



**Warning!** Risk of eye injury.



### General safety information

**Read this Quick Start and Safety Manual carefully before installing, using or servicing the product.**

If you have any doubts or questions about how to use the product safely, contact your GLP® supplier for assistance. Your GLP supplier will be happy to help.

The user documentation for GLP® KNV lighting fixtures consists of:

- The KNV Quick Start and Safety Manual, supplied with KNV fixtures and available for download from [www.glp.de](http://www.glp.de). The Quick Start and Safety Manual contains important safety information and installation instructions that the installer and user must read.
- The KNV User Manual, available for download from [www.glp.de](http://www.glp.de). The User Manual explains features and control of KNV fixtures.
- The KNV DMX Channel Index, available for download from [www.glp.de](http://www.glp.de). The Channel Index is a separate guide to the DMX control channel layout and DMX commands available.

All documents are available for download from [www.glp.de](http://www.glp.de).

The KNV is intended for use by experienced professionals with the knowledge and skills to set up, operate, and maintain high-powered, remotely controlled lighting equipment safely and efficiently. These operations require expertise that may not be provided in this Manual and the User Manual.

- Respect all warnings and directions given in the product's user documentation and on the product. Read the user documentation and familiarize yourself with the

safety precautions it contains before installing or using the product. GLP and affiliated companies will take no responsibility for damage or injury resulting from disregard for the information in the user documentation.

- Check the GLP website at [www.glp.de](http://www.glp.de) and make sure that you have the latest version of this Quick Start and Safety Manual. Check the fixture software version indicated on page 2 of this manual and then use the fixture's control panel to check the version installed in the fixture. If the versions are not the same, this manual may still cover the fixture, because software updates do not always affect the way you use the fixture. However, it is possible that this manual does not match the fixture perfectly. Software release notes can help clarify this question. You can consult software release notes and download the correct version of this manual on the GLP website if necessary.
- Make all user documentation – this Quick Start and Safety Manual as well as the User Manual – available to all installers and operators. Save both documents for future reference.
- If you have any questions about the safe operation of the product, please contact an authorized GLP distributor (see list of distributors at [www.glp.de](http://www.glp.de)).
- Use the product only as directed in this manual. Observe all markings in this manual and on the product.
- Refer all repairs and any service operation not described in this manual to a technician authorized by GLP.
- The light source in this product must not be changed by the end user.
- Read and follow the user documentation for all additional equipment.



### **Electrical safety**

- Do not allow the product to become immersed. Do not expose the product to high-pressure water projections.
- Keep any unused connectors on the product sealed with their protective caps at all times, both when the product is in use and when not in use.
- Use only a source of AC mains power that complies with local building and electrical codes and has both overload and ground fault (earth fault) protection.
- Ensure that the product is electrically connected to ground (earth).
- Disconnect the product from AC mains power before carrying out any installation or maintenance work and when the product is not in use.
- Disconnect the product from power immediately if any seal, cover, cable, connector or other component is damaged, defective, deformed or showing signs of overheating. Do not reapply power until the product has been repaired and made safe by a technician authorized by GLP.

- Check that all power distribution equipment, cables and connectors are in perfect condition, rated for the electrical requirements of all connected devices, suitable for their application and suitable for the installation environment.
  - Use only Neutrik PowerCON TRUE1 cable connectors for AC mains power input at the product's Mains IN connector and for relaying AC mains power from one fixture's Mains OUT (Thru) connector to another fixture's Mains IN connector.
  - Use minimum 14 AWG or 1.5 mm<sup>2</sup> power input and relay cables that are minimum 16 A-rated and temperature-rated to suit the application. In the USA and Canada the cables must be UL-listed, type SJT or equivalent. In the EU the cables must be type H05VV-F or equivalent.
  - Do not connect devices to power in a chain if the total maximum current draw of all the devices in the chain when added together will exceed the current rating of any cable or connector used at any point in the chain. The supplied power input cable is rated as follows:
    - US power cable: 16 A, 14 AWG, UL listed, E304117, SJT, 4.9 ft.
    - EU power cable: 16 A, 1.5 mm<sup>2</sup>, H05VV-F, 1.5 m.
- Do not connect more than two (2) KNV fixtures to power in a chain at 100-120 V, 60 Hz.
- Do not connect more than four (4) KNV fixtures to power in a chain at 200-240 V, 50 Hz.
- The voltage and frequency at the Mains OUT socket are the same as the voltage and frequency applied to the Mains IN socket. Only connect devices to the Mains Out socket that accept this voltage and frequency.
  - KNV fixtures do not have a user-replaceable fuse. If you suspect that a fuse has blown, disconnect the fixture from power and send it to a technician authorized by GLP for repair.



### **Fire safety and protection from burns**

- Do not operate the product if the ambient temperature (Ta) exceeds 45° C (115° F).
- The surface of the product's casing can reach up to 65° C (149° F) and the front screen can reach 80° C (176° F) during operation. Avoid contact by persons and materials. Do not install the product in a location where there is a risk of accidental contact. Allow the product to cool for at least 20 minutes before handling
- Keep the product well away from flammable materials.
- Keep all combustible materials (e.g. fabric, wood, paper) at least 0.2 m (8 in.) away from the product.
- Ensure that there is free and unobstructed airflow around the product. Provide a minimum clearance of 100 mm (4 in.) around fans and air vents.



- Do not illuminate surfaces within 1 m (3.3 ft.) of the product. The light output from the product is powerful enough to cause burns or fire in illuminated objects at close range.
- Do not place any optical components other than KNV accessories onto the front of the fixture.
- Do not stick filters, masks or other materials onto the fixture. Do not block the light output in any way. The front surface becomes hot during operation and can melt or ignite objects that are in contact with the surface. Ensure that the front surface is clean and unobstructed at all times in order to prevent a fire hazard and damage to the fixture.
- The product's optical components can focus the sun's rays, creating a risk of fire and damage. Do not expose the front of the product to sunlight or any other intense light source, even from an angle.



### Eye safety

- The KNV is classified as a Risk Group 3 lighting fixture according to EN 62471. Possibly hazardous radiation emitted. Do not stare into the light output from the product. May be harmful to the eyes.
- Do not look at the product's light output with optical instruments or any device that may concentrate the light output.
- Make sure that persons near to or working on the product are not looking directly into the light output when the product lights up suddenly. This can happen when power is applied, when the product receives a DMX signal, or when certain control menu items are selected.
- The warning below is printed on the product. If the warning becomes impossible to read, replace it with a label reproduced from this illustration:

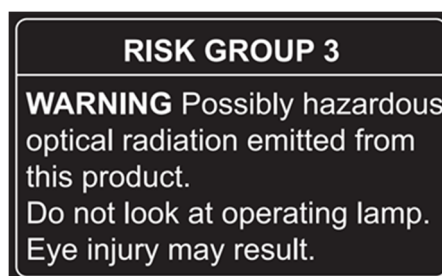

- Provide well-lit conditions to reduce the pupil diameter of anyone working on or near the product.



### Strobe safety

- Flashing light, particularly at 5 - 30 Hz, may cause seizures in persons with photosensitive epilepsy. Do not use strobe effects for extended periods.
- Comply with local regulations on the use of strobe lighting and notify the public in advance with highly visible warning signs when strobe effects are used.
- If a seizure occurs, stop using strobe effects. Seek professional medical help. Note the time that the seizure starts and finishes. Call emergency medical help urgently if the seizure lasts more than five minutes, if it is the person's first seizure, or if the person is injured. While waiting for help to arrive, protect the affected person from injuring themselves on hard or sharp objects. If necessary, move the person to a safe place. Lay them on their side with their head supported to prevent it from hitting the floor. Loosen any tight clothing around their neck. Do not use force to hold the person or restrict their movements. Do not put anything in their mouth, including your fingers.



### Installation safety and protection from personal injury

- Installation must be performed by qualified personnel only and carried out in accordance with applicable regulations such as DIN VDE 0711-217.
- The product is not portable when installed.
- Ensure that the supporting structure and installation hardware used can hold at least ten times the weight of the load that they support.
- Fasten the product to a structure or surface only as directed in this manual and only with hardware that is specifically designed and rated for its purpose. Do not use a safety cable as the primary means of support. Check that installation hardware is in perfect condition. Fasteners must be steel grade 8.8 strength or better. Rigging clamps must be half-coupler type that completely encircle the rigging truss chord.
- If the product is installed in a location where it may cause injury or damage if it falls, install as directed in this manual a safety cable or similar secondary attachment that will hold the product if a primary attachment fails. The secondary attachment must be approved by an official body such as TÜV as a safety attachment for the weight that it secures, it must comply with EN 60598-2-17 Section 17.6.6, and it must be able to support a static suspended load that is ten times the weight that it secures.
- If the product is installed in a location where it may be exposed to forces such as wind pressure, vibration or movement, make sure that the installation can withstand these forces. Monitor weather forecasts constantly. Take down the installation immediately if there is any risk of weather conditions that could destabilize the installation.

- Check that all covers and items of rigging hardware are secure before using the product. Do not operate the product with missing or damaged covers, shields or any optical component.
- Restrict access below the work area and work from a stable platform whenever installing, servicing or moving the product.
- If the product becomes damaged, stop using it immediately and disconnect it from power. Do not attempt to use a product that is obviously damaged.
- Do not modify the product in any way not described in its user documentation.
- Install genuine GLP parts only.

## 2. Avoiding damage to the fixture

**Important! Follow the directions in this section carefully, or the fixture may suffer damage that is not covered by the product warranty.**

### General precautions

Do not drop the fixture or expose it to mechanical stress.

Protect the LCD display and control panel from shocks, or they may suffer damage that is not covered by the product warranty.

Do not expose the fixture to heat (from other lighting fixtures for example).

Clean optical components only as directed. Oils, solvents, and other chemicals commonly used for cleaning can damage the lens coatings and surfaces.

Use only original spare parts. Do not make any structural modifications to the fixture or you will void the product warranty.

### Avoiding damage from light sources

Do not point the front of the fixture towards the sun or other strong light sources. Strong light can cause internal damage to the fixture, melting components or starting an internal fire within seconds.

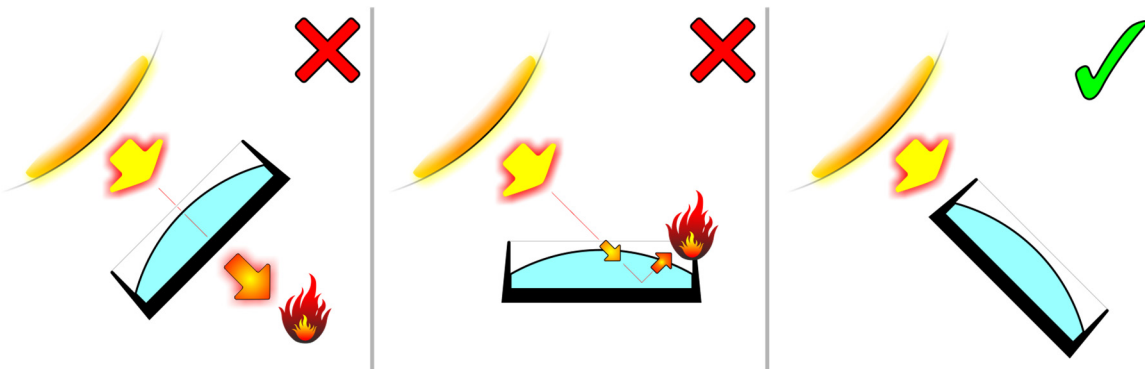

**Figure 1. Avoiding damage from light sources**

Damage can occur whether the fixture is powered on or off. See Figure 1. Damage can also occur if the light hits the front of the fixture at an angle: the fixture does not need to be pointing *directly* at the sun or other light source.

To avoid problems from strong light sources:

- Do not expose the front of the fixture to sunlight or any other strong light source.
- In outdoor applications during daylight, make sure that the front face of the fixture is shielded or points away from the sun, even when not in use.
- Do not aim other high-powered beam lights directly at the fixture.

## IP rating

KNV fixtures are IP54-rated:

- **IP** stands for Ingress (entry into the fixture) Protection.
- The figure **5** in the rating means that fixtures are protected against the entry of solid bodies larger than 1 mm (fingers, tools, etc.) and have limited protection against the entry of dust and airborne particles.
- The figure **4** in the rating means that fixtures are protected against the entry of rain and water spray (splashing) that arrives from vertically above or at an angle of up to 60° from vertically above the fixture. Fixtures are not protected against immersion in water and they are not protected against low or high-pressure water jets.

## Avoiding damage from water and humidity

- Do not install KNV fixtures in a location where water can pool around the fixture or allow KNV fixtures to become submerged in any other way. Do not aim low- or high-pressure water jets at fixtures.
- Keep all unused connectors on the fixture sealed with their protective caps, both when the fixture is being used and when it is not in use.
- In outdoor and high-humidity environments, use IP65-rated power and data connectors and cable (an IP65 rating means that the item is protected against the entry of water from rain, projections and low-pressure jets as well as the entry of dust). When assembling connectors and installing them on cable, follow the manufacturer's instructions (see [www.neutrik.com](http://www.neutrik.com)) and ensure that an IP65 rating is maintained for the complete assembly. Use only the following connectors:
  - Neutrik NE8MX6 for data IN and OUT (THRU)
  - Neutrik NAC3FX-W for Power IN
  - Neutrik NAC3MX-W for Power OUT (THRU).
- Apply a dielectric grease (available from most electrical suppliers) to connector terminals and caps to prevent corrosion and/or electrical short circuits.
- Make sure that cables open into dry areas or sealed junction boxes. Moisture can be drawn along cables by capillary action or pressure variations resulting from thermal expansion.
- See drawing on right. Arrange cables so that they arrive at connectors from below. Make sure that it is impossible for water to flow down cables and accumulate at connectors. If necessary, provide extra cable slack and create 'drip loops' before connectors.
- Create loose cable bends only. Do not subject connections to bending forces or allow connections to bear the weight of long lengths of cable.

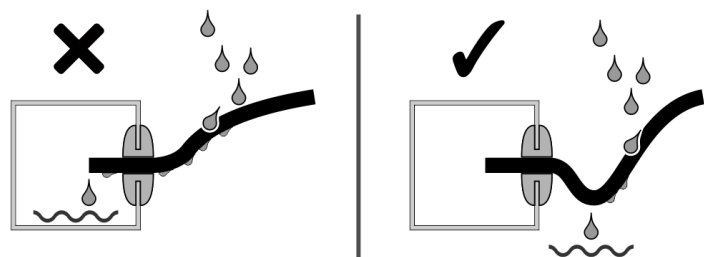

### **Avoiding damage from dust and airborne particles**

- Carry out regular visual inspections of every fixture to make sure that there is no accumulation of dirt, especially on the front of the fixture and on air vents.
- If cleaning is necessary, follow the instructions in 'Cleaning and maintenance' on page 35.

### **Transportation and storage**

- Transport the fixture either in a flightcase or in its original packaging to protect it from damage caused by shocks during transportation.
- Store the fixture in a dry location when not in use.

### 3. KNV Cube overview

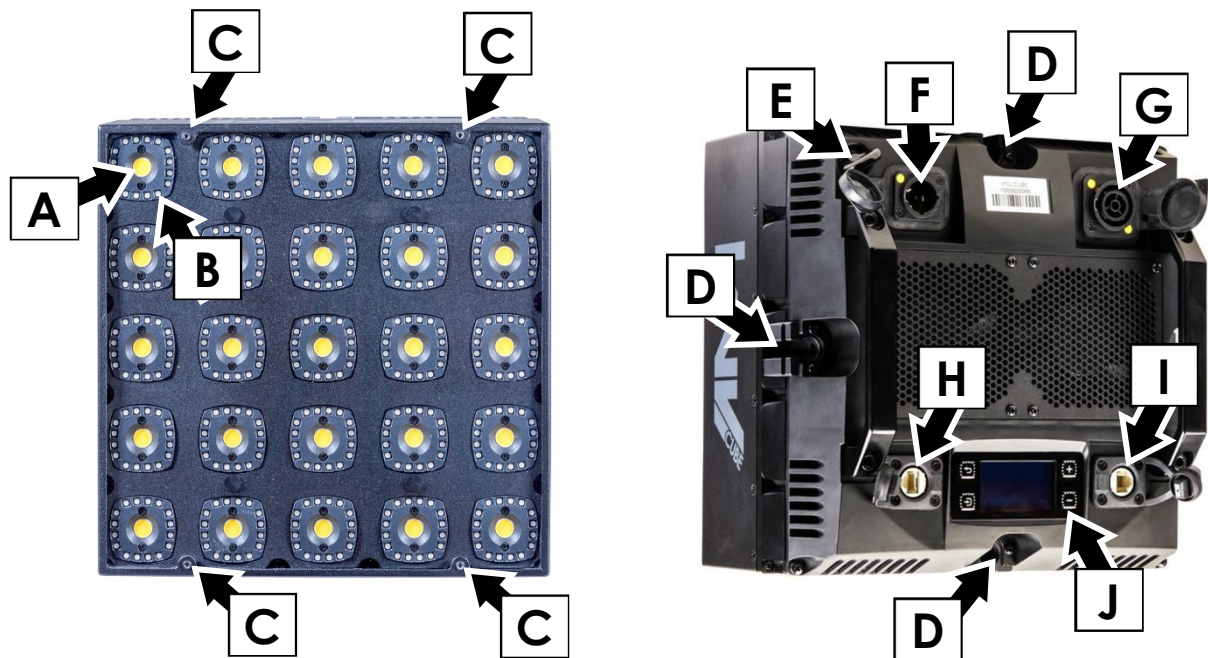

Figure 2. Cube overview

- A – White LED
- B – RGB LEDs
- C – Mounting points for optical accessories
- D – Mechanical connector attachment points
- E – Safety cable attachment point
- F – AC mains power IN (Neutrik powerCON TRUE1)
- G – AC mains power OUT / THRU (Neutrik powerCON TRUE1)
- H – Neutrik EtherCON port for control data (DMX/Art-Net/sACN in/out)
- I – Neutrik EtherCON port for control data (DMX/Art-Net/sACN in/out)
- J – Control panel with backlit LCD display

#### 4. KNV Arc overview

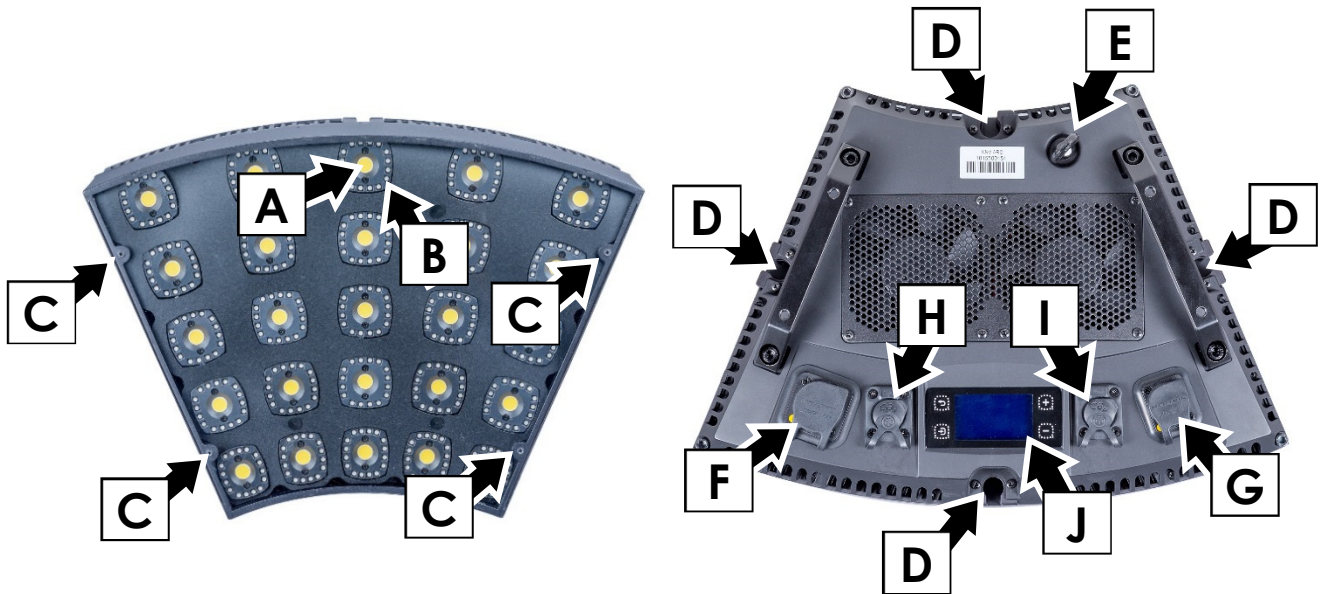

Figure 3. Arc overview

- A – White LED
- B – RGB LEDs
- C – Mounting points for optical accessories
- D – Mechanical connector attachment points
- E – Safety cable attachment point
- F – AC mains power IN (Neutrik powerCON TRUE1)
- G – AC mains power OUT / THRU (Neutrik powerCON TRUE1)
- H – Neutrik EtherCON port for control data (DMX/Art-Net/sACN in/out)
- I – Neutrik EtherCON port for control data (DMX/Art-Net/sACN in/out)
- J – Control panel with backlit LCD display



## 5. Features

The KNV can be used indoors in permanent and temporary installations. Its rugged construction and IP54 rating mean that it can also be used outdoors in temporary installations if precautions are taken to prevent immersion in water and damage from direct sunlight. Fixtures can be placed upright on a level surface or suspended from a suitable structure as directed in this manual.

Power and data can be daisy-chained and products interlocked for ease of installation.

The range of installation hardware items available from GLP allows KNV fixtures to be installed in an endless number of creative configurations.



**Figure 4. Example combinations of KNV Cube and Arc fixtures**

The KNV is not suitable for household use, for use in any location where unattended children have access to it, or for use in permanent outdoor installations.

### Fixture control

This Quick Start and Installation Manual gives a very basic overview of control options and functions. See the KNV User Manual available for download from [www.glp.de](http://www.glp.de) for full details of control, pixel layout, etc.

## 6. Installation



**Warning!** Read 'Safety' starting on page 5 for important safety information that you must understand before you install or operate the fixture. Install KNV fixtures only as described in this chapter, or you may create an installation that is unsafe.

KNV Cube and Arc fixtures can be installed in endless creative configurations, and the flexibility of the products places extra demands on the installer. The installer must both respect the instructions and warnings given in this chapter and use their professional experience and knowledge to ensure that the installation is safe.

When installing, keep the fixture at least 0.2 m (8 in.) away from flammable materials including curtains and stage scenery and 1 m (3.3 ft.) away from any surface that will be illuminated.

It is the installer's responsibility to provide a stable, secure supporting structure that is suitable for the environment and application. The structure must be capable of safely supporting at least ten times the weight of all the devices and hardware that will be installed on it.

### Permitted mounting options

A KNV Cube fixture may be installed in one of the following ways only:

1. Standing in a KNV Floorstand-Bracket on a level, stable surface.
2. Suspended from a rigging truss or similar structure with one single fixture hanging vertically in a KNV Floorstand-Bracket or a KNV Installation Bracket.
3. Suspended from a rigging truss or similar structure with one single fixture – or up to a maximum of four (4) fixtures interconnected using KNV Module Connectors – hanging vertically from a KNV Rigging Connector and half-coupler rigging clamp.

A KNV Cube or KNV Arc fixture may be installed in one of the following ways only:

4. Supported by a KNV Installation Bracket that is fastened to a rigging truss or similar structure at any angle using a half-coupler rigging clamp.
5. Supported on both sides by two KNV fixtures that are fastened to it using KNV Module Connectors. Each of these two fixtures must be fastened to a rigging truss or other structure at any angle using a half-coupler rigging clamp.

## Installation hardware

The following items of installation hardware are available from GLP for the KNV. Use them only as directed in this chapter. Respecting all warnings on the hardware and in this manual.



### KNV Cube Floorstand-Bracket

Adjustable.

May be used to stand one KNV Cube fixture on a level, stable surface.

May be used to support one KNV Cube fixture only hanging vertically downwards from a rigging truss, bar or similar support.



### KNV Installation Bracket

Non-adjustable.

May be used to fasten a KNV Cube or Arc to a supporting structure.

May be used in combination with rigging clamps to provide the required points of support in larger and creative arrays of KNV Cube and/or Arc fixtures.

Both latches must be pushed inwards to lock.



### KNV Module Connector

May be used to lock two KNV fixtures to each other vertically and side-by-side.

Handle must be twisted 90° to lock.



### KNV Rigging Connector

May be fastened to a KNV and used as a rigging clamp attachment bracket.

May be used to support up to a maximum of four KNV fixtures that are locked together and suspended vertically.

*If you want to suspend more than four fixtures in an array, you will need to provide additional supports and KNV Installation Brackets as described in this manual.*

Handle must be twisted 90° to lock.

## Mechanical connectors

See Figure 5. Channels (arrowed) are provided on the top, bottom, left and right sides of KNV fixtures. These channels accept the mechanical connectors on the KNV Brackets, Fixture Connectors and Rigging Connectors. The system lets you lock brackets to fixtures and lock fixtures to each other quickly and securely. Each channel incorporates a safety mechanism that allows a mechanical connector to be locked into the channel.



**Figure 5. Mechanical connector channel**

## Fastening fixtures to each other



**Warning!** Do not use a KNV Module Connector to support the weight of a fixture held horizontally or at any other angle from vertical.

Do not use a KNV Module Connector to support the weight of more than four fixtures.

You can use KNV Module Connectors to fasten a maximum of four (4) fixtures in total together in a column that is suspended vertically. You can use these connectors to fasten an unlimited number of fixtures side-by-side, provided that fixtures are safely supported as described in this manual.

To fasten two KNV Cube and Arc fixtures to each other:

1. See Figure 6. Carefully place the fixtures front-down on a clean, flat surface so that their connector channels are next to each other.
2. Push a KNV Module Connector **A** fully into the connector channels **B** on both fixtures.
3. Push the locking handle **C** down, twist it 90° clockwise so that the locking plate **D** engages in both fixtures, then release the handle.
4. Check that the KNV Module Connector cannot slide out of a channel in either fixture and that both fixtures are locked securely together.

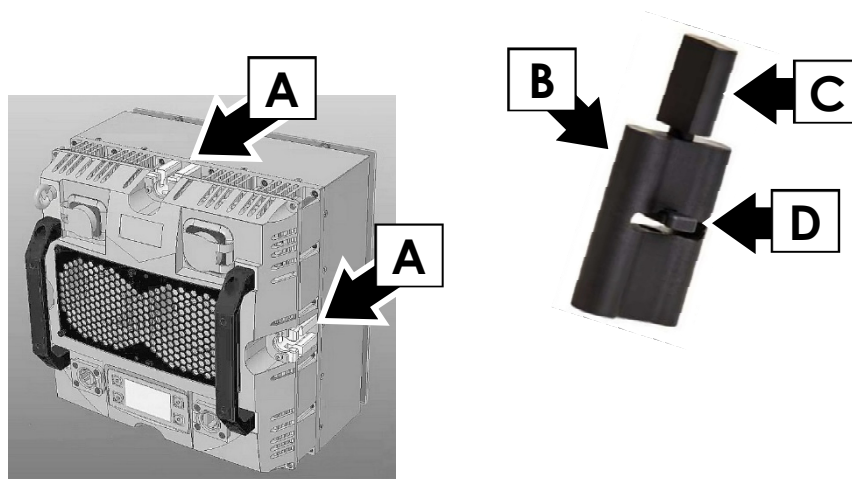

**Figure 6. Using a KNV Fixture Connector**

### Using KNV connector plates



**Warning!** The connector plates available for KNV fixtures may be used for alignment and as secondary attachment only. Do not use a KNV connector plate with or without a rigging clamp to support weight as a primary attachment.

KNV connector plates have a central hole for an M12 bolt. This hole may be used to fasten a rigging clamp to the connector plate, but the rigging clamp may be used for lateral support only. Do not use it to for weight-bearing.

Connector plates may be fastened to the handles on the back of KNV Cube and Arc fixtures using the supplied Allen bolts to align fixtures, but fixtures must be locked together with KNV Module Connectors before connector plates are installed.

See Figure 7. KNV connector plates screw into the handles on the back of fixtures using the four Allen bolts supplied with each connector plate.

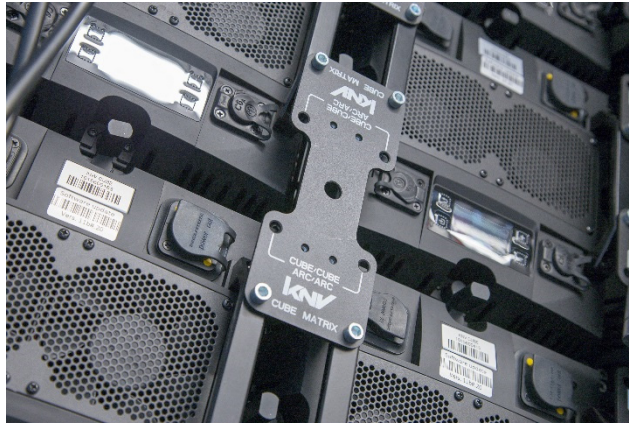

**Figure 7. KNV Multi Connector Plate**

The following connector plates are available for KNV fixtures:

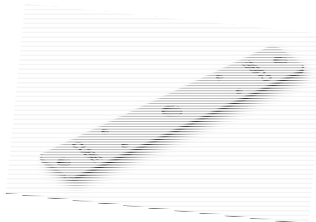

#### **KNV Connector Plate CC**

CC Connector plates (see **A** in Figure 8) are designed for Cube-to-Cube alignment. Use them to:

- align the edges of Cube fixtures that are suspended in a column, or
- align the outer edges of an array of Cube fixtures.



#### **KNV Connector Plate CA**

CA Connector Plates (see **B** in Figure 8) are designed for Cube-to-Arc alignment. Use them to align Cube and Arc fixtures side-by-side.



#### **KNV Multi Connector Plate**

Multi Connector Plates (see **C** in Figure 8) are designed for three purposes. Use them to:

- align Cube-to-Cube fixtures horizontally,
- align Arc-to-Arc fixtures side by side, and
- align more than two Cube-to-Cube fixtures when creating a multiple fixture matrix.

Figure 8 shows KNV Connector Plates in use. Note that the fixtures in Figure 8 are locked together using KNV Module Connectors and that the KNV Connector Plates are added for alignment purposes only. Do not use KNV Connector Plates to support weight.

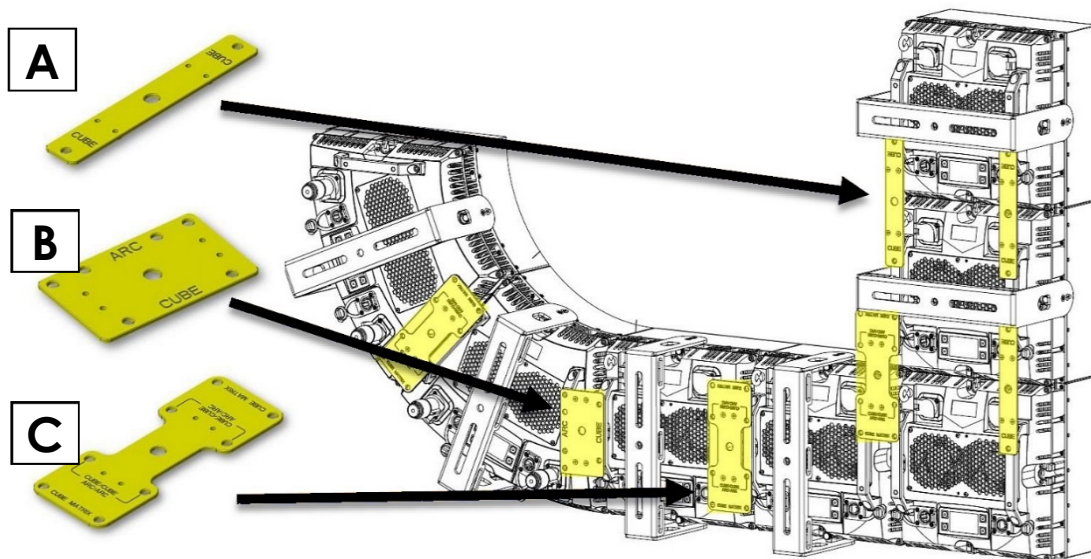

**Figure 8. KNV Connector Plates in use**

### Standing a Cube upright on a level surface

KNV Cube fixtures may be placed standing upright on a surface using the supplied KNV Cube Floorstand-Bracket.

To use the Floorstand-Bracket as a floorstand for a KNV Cube fixture:

1. Move the legs of the bracket to the fully open position at about 90° apart as shown in Figure 9.
2. Open the safety latches on both sides of the bracket by moving the slider to the outside position.
3. Slide the connector profiles on the arms of the bracket into the KNV Cube connector channels (see Figure 5 on page 19).



**Figure 9. KNV Cube placed on a surface using the Floorstand-Bracket**

4. Close the safety latches on both sides of the bracket by moving their sliders to the inside position. Each slider is held in place by a spring-loaded retaining mechanism.
5. Check that the fixture is held securely in the bracket.
6. If necessary, loosen the handscrews (arrowed in Figure 9) on both sides of the bracket and adjust tilt.
7. Check that the handscrews on both sides of the bracket are tight so that the fixture cannot rotate in the bracket.
8. Place the fixture and floorstand on a level, stable surface where the fixture and cables will not present a danger. Make sure that persons cannot accidentally touch the fixture when it is installed.

### Securing fixtures with a safety cable

If a fixture can cause injury or damage if it falls, secure it as soon as you have fastened it into position with a secondary attachment such as a safety cable that is approved for the weight that it secures.

Each fixture must have its own safety cable except for installations where four fixtures are fastened together with KNV mechanical connectors plus KNV connector plates on both sides of the fixtures and suspended in a vertical column from a KNV Rigging Connector. In this configuration, it is acceptable to secure the top fixture with a safety cable that is approved for the weight of the four fixtures plus rigging hardware. The three fixtures hanging below the top fixture are secured against the failure of the mechanical connectors (primary attachments) by two connector plates (secondary attachments) per fixture.

To secure a KNV Cube or Arc fixture with a safety cable:

1. Loop the safety cable around a secure anchoring point such as a truss chord or bar so that it will catch the fixture if a rigging clamp fails. Take up as much slack as possible in the safety cable (by looping it more than once around the truss chord, for example).
2. See Figure 10. Fasten the safety cable to the attachment eyelet (arrowed) in the back of the fixture and check that the fixture is now secured.

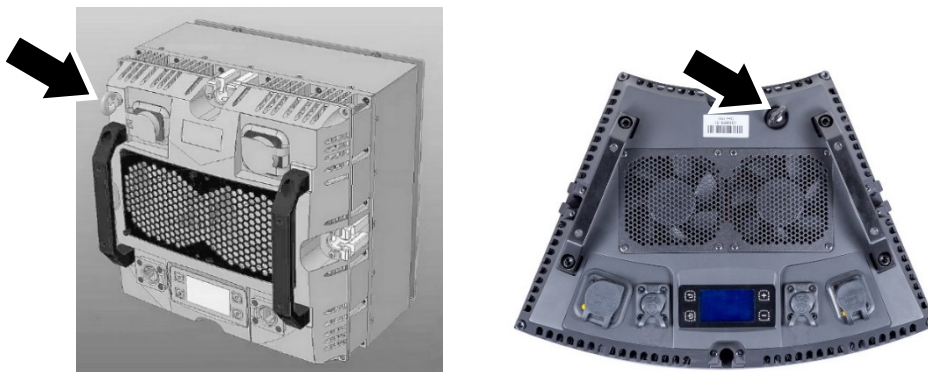

**Figure 10. Safety cable attachment points**



## Using KNV Installation Brackets

The KNV Installation Bracket fastens into the channels arrowed in Figure 11: four channels on KNV Cube and two channels on KNV Arc fixtures.

The elongated holes in the bracket let you fasten a half-coupler rigging clamp to the bracket and then fasten a Cube or Arc fixture to a straight bar or truss chord at any angle. The elongated holes also let you fasten Arc fixtures to an F31 circular truss or truss piece to create a circular or curved array with an external diameter of 1000 mm (39.4 in.).

To fasten a KNV Installation Bracket to a Cube or Arc fixture:

1. Slide the rounded profiles in the open ends of the installation bracket fully into two of the connection channels (arrowed in Figure 11) on the fixture.

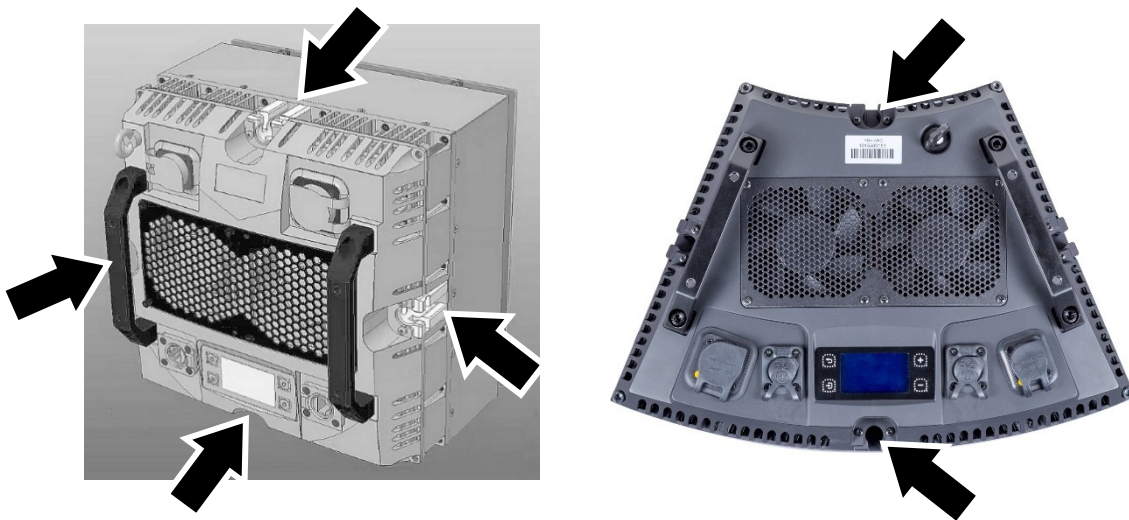

**Figure 11. Connection channels for Installation Bracket**

2. See Figure 12. Slide the safety latches on both sides of the installation bracket inwards towards the fixture to lock the rounded profiles on the bracket into the connection channels. The latches snap into place under spring pressure.

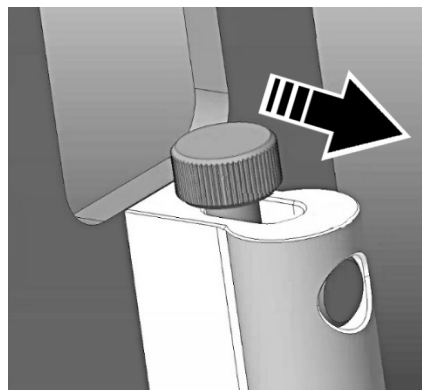

**Figure 12. Safety latch on Installation Bracket**

3. Check that the bracket is locked to the fixture securely on both sides.
4. If you are going to fasten the fixture to a rigging truss or similar structure, bolt an approved half-coupler rigging clamp as close as possible to the center of the Installation Bracket using an M12 bolt, grade 8.8 steel or better, and self-locking nut.

### Suspending a single fixture



**Warning!** See Figure 14 on page 26. You may use the KNV Floorstand-Bracket to suspend one KNV Cube hanging vertically downwards only. Do not use the Floorstand-Bracket to support the weight of more than one fixture. Do not use the Floorstand-Bracket to support a fixture at any other angle than hanging vertically downwards.

Using the supplied KNV Floorstand-Bracket, you can suspend one single KNV Cube hanging vertically downwards from a rigging truss or similar structure.

To suspend a KNV Cube fixture from the Floorstand-Bracket:

1. Turn the legs of the bracket to the fully closed position so that the legs are parallel as shown in Figure 13.
2. Open the safety latches on both sides of the bracket by moving the slider to the outside position.
3. Slide the connector profiles on the arms of the bracket into the KNV Cube connector channels (see Figure 5 on page 25).
4. Lock the safety latches on both sides of the bracket by moving their sliders to the inside position. Each slider is held in place by a spring-loaded retaining mechanism.
5. Check that the fixture is held securely in the bracket.

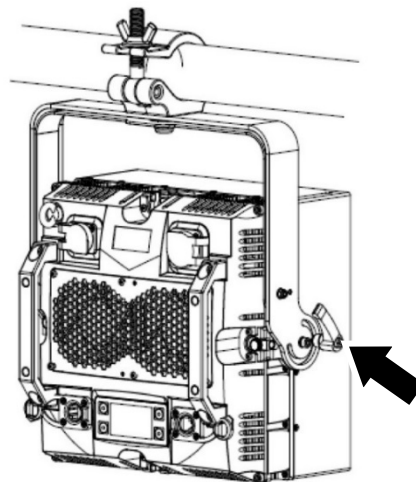
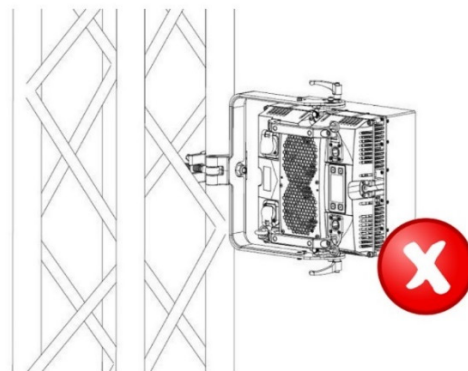

**Figure 13. Single KNV Cube suspended in Floorstand-Bracket**

Take a rigging clamp that is approved for the weight of the fixture and bracket and fasten the clamp to the center of the bracket yoke as shown in Figure 13 using an

M12 bolt, grade 8.8 steel minimum, and self-locking nut. The bolt must pass through both legs of the bracket.

6. Fasten the rigging clamp securely to a truss chord or similar rigging structure.
7. If the fixture may cause injury or damage if it falls, secure it immediately with a safety cable as described earlier in this chapter (see 'Securing fixtures with a safety cable' on page 23).
8. If necessary, loosen the handscrews (arrowed in Figure 13) on both sides of the bracket and adjust tilt. Retighten the handscrews and check that the fixture is held securely.



**Figure 14. Floorstand-Bracket – do not use at any other angle than vertical**

### Installing an array of multiple fixtures



**Warning!** See Figure 15. Do not use the Floorstand-Bracket to support more than one fixture. Use a KNV Rigging Connector and half-coupler rigging clamp to suspend a maximum of four fixtures total in a vertical column.

To create an array of multiple fixtures, you can use one of two options:

- Suspend a column of maximum four KNV Cube fixtures vertically from a rigging truss or similar structure using a KNV Rigging Connector and half-coupler clamp to support the top fixture and KNV Module Connectors to support up to three fixtures hanging from the top fixture. Then suspend the next vertical column beside the first, aligning the columns side by side using KNV Multi Connector Plates, and so on. Suspend other columns of maximum four Cube fixtures from separate support points above and below the first columns, if required.
- Arrange a suitable supporting structure and fasten each individual KNV Cube or Arc fixture to it using one KNV Installation Bracket and one half-coupler clamp per fixture. There is one exception to the requirement for each fixture to have its own independent bracket and clamp: use of a KNV Installation Bracket and half-coupler clamp is not required on any fixture that is connected on two sides to fixtures that are correctly supported.

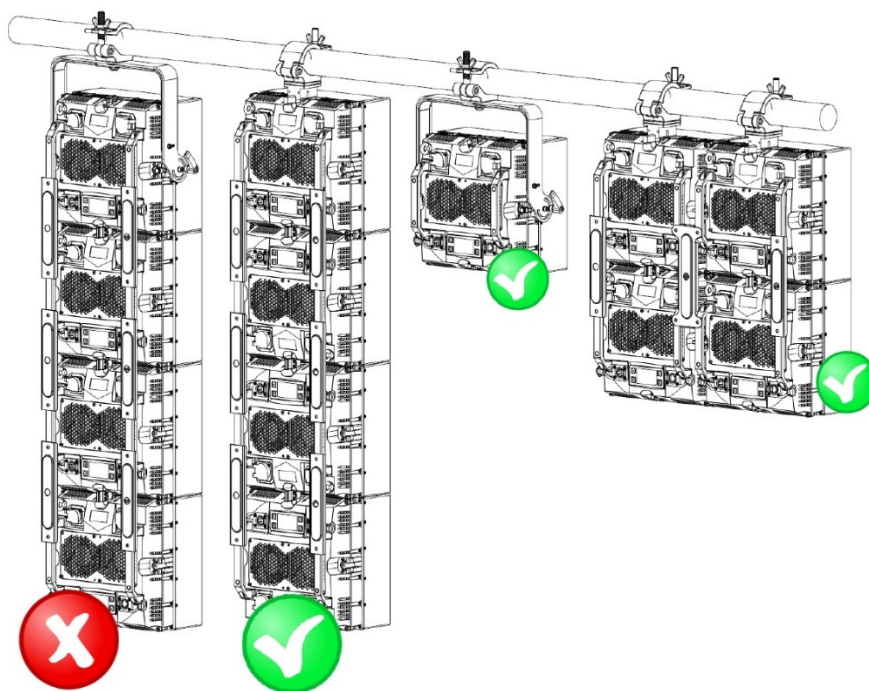

**Figure 15. Installation hardware for suspending multiple fixtures**

### Installing a curved or circular array

You can fasten KNV Arc fixtures to each other to create curves or full circles.

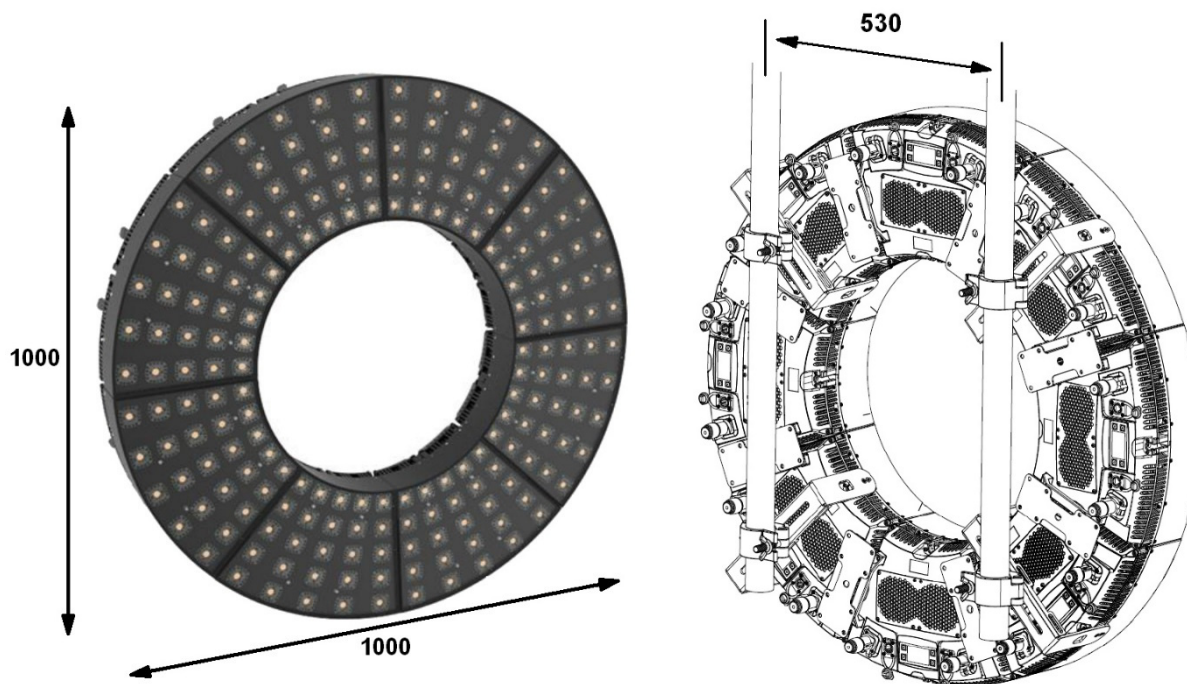

**Figure 16. KNV Arc circular array dimensions**

See Figure 16. A full circle of KNV Arc fixtures has an external diameter of 1000 mm (39.4 ins.). The minimum amount of hardware required for supporting a full circle is: two mounting bars or truss chords 530 mm (20.9 in.) apart, four KNV Installation Brackets, four half-coupler rigging clamps and eight KNV Multi Connector Plates as shown in Figure 16.

To create a curved or circular array of KNV Arc fixtures, you must provide a safe, stable supporting structure that will provide the necessary mounting points and that is capable of safely supporting ten times the weight that will be installed on it.

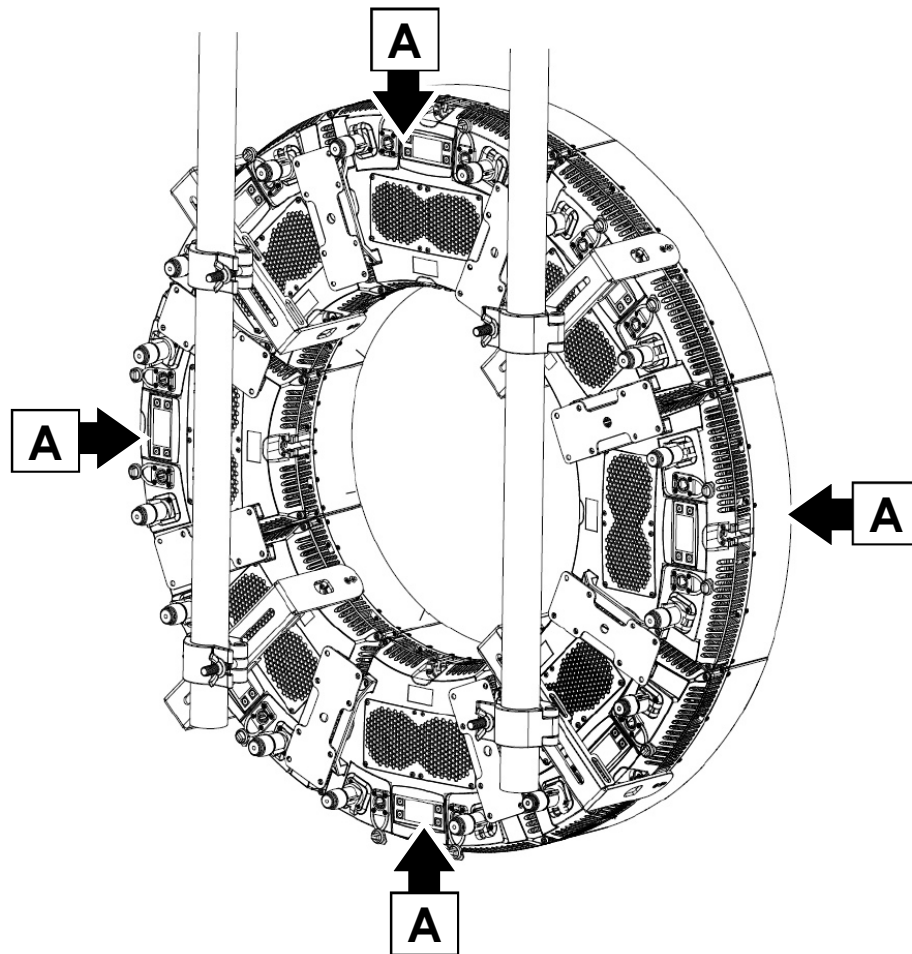

**Figure 17. Supporting KNV Arc fixtures in a circular array**

Each KNV fixture must be fastened to the supporting structure using one KNV Installation Bracket and half-coupler clamp per fixture. There is one exception to this: if a fixture is fastened with KNV Module Connectors and KNV Connector Plates to two fixtures (one fixture on either side) that are supported by KNV Installation Brackets and half-coupler clamps, it does not need to be supported by its own KNV Installation Bracket. In other words, a fixture that is 'sandwiched' between two correctly supported fixtures (like the fixtures marked **A** in Figure 17) does not need an Installation Bracket. Likewise, a fixture that is 'sandwiched' in this way does not need to be secured with its own safety cable. All other fixtures in a curved or circular array must be

secured with a safety cable as described in 'Securing fixtures with a safety cable' on page 23.

To install a curved or circular array of KNV Arc fixtures:

1. Fasten a KNV Installation Bracket and half-coupler rigging clamp to every fixture or every second fixture.
2. See Figure 17. Fasten the first fixture to the supporting structure by means of its Installation Bracket and rigging clamp.
3. Add fixtures, fastening them to each other using KNV Module Connectors, aligning them by fastening KNV Multi Connector Plates to their handles, and fastening them to the supporting structure using the installation brackets and half-coupler clamps.
4. Each time you install a fixture on the supporting structure, secure it immediately with a safety cable as described earlier in this chapter (see 'Securing fixtures with a safety cable' on page 23) if it may cause injury or damage if it falls.

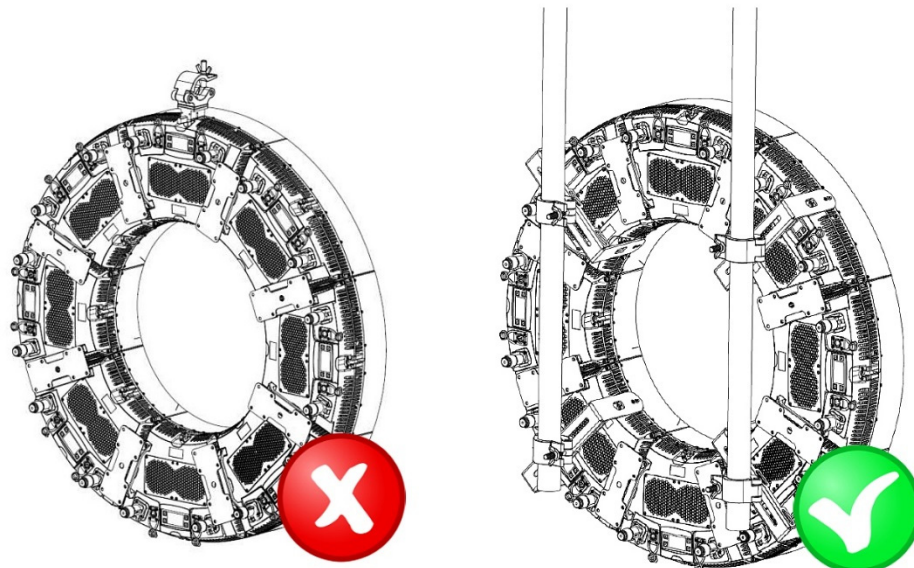
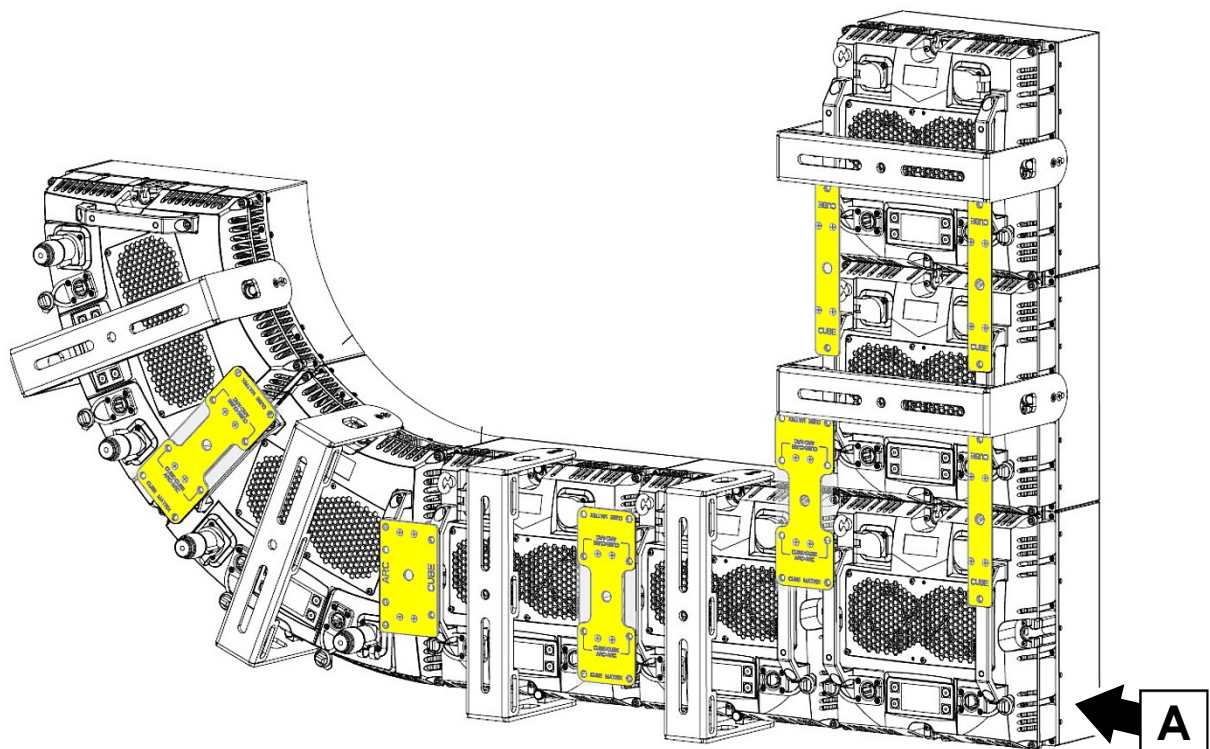

**Figure 18. Supporting a circular array of KNV Arcs**

## Installing a creative array

To install a creative array consisting of a mixture of KNV Cube and Arc fixtures, see Figure 19.

1. Fasten a KNV Installation Bracket and half-coupler rigging clamp to every fixture or every second fixture.
2. Fasten the first fixture to the supporting structure by means of its installation bracket and rigging clamp.
3. Add fixtures, fastening them to the supporting structure using their installation brackets and rigging clamps, fastening them to each other using KNV Module Connectors, and aligning them with the existing fixtures using KNV Connector Plates fastened to their handles with the supplied Allen screws. You must use one bracket and rigging clamp per fixture unless a fixture (like fixture **A** in Figure 19) is fastened on at least two sides to fixtures that are supported using installation brackets and rigging clamps.
4. Each time you install a fixture on the supporting structure, secure it immediately with a safety cable as described earlier in this chapter (see 'Securing fixtures with a safety cable' on page 23) if it may cause injury or damage if it falls.



**Figure 19. Creative array: example**

## 7. AC mains power



**Warning!** Read 'Safety' starting on page 5 for important safety information that you must understand before you install or operate the fixture.

Check that all cables and connectors are suitable for the installation environment and application (see recommendations in 'Avoiding damage to the fixture' on page 11).

Keep connectors sealed with their rubber caps at all times when not in use.

### Included items

The KNV is supplied with a power cord with Neutrik powerCON TRUE1 connector.

### Connecting to power

The AC mains power supply must include a connection to ground / protective earth. It must be protected against ground / earth leakage and overload. The fixture's internal auto-sensing power supply accepts AC power at 100-240 V, 50/60 Hz. Do not connect the fixture to power at any other voltage or to an external dimmer.

The KNV does not have a power ON/OFF switch. Power is applied to the fixture as soon as the power cable becomes live.

The KNV has a 3-conductor Neutrik powerCON TRUE1 Mains IN power input socket that accepts AC power from a TRUE1 female cable connector. Although TRUE1 connectors support hot-plugging, it is still good practice to shut down power to power cables before connecting them to fixtures.

To connect the fixture to power:

1. If possible, shut down power to the power input cable.
2. Note the position of the keys and keyways on the TRUE1 power cable connector and Mains IN socket and align them with each other. Insert the cable connector into the socket and twist clockwise to lock.
3. Before applying power by energizing the power cable, check that nobody is looking directly into the front of the fixture.

To disconnect the fixture from power, pull the latch on the cable connector outwards to release it, then twist the connector counterclockwise and pull to remove it from the socket.

### Installing power connectors

It is possible to install a cord cap / mains power plug that is suitable for your local convenience receptacles / mains power sockets on the supplied power input cable. If you do this, check that the cord cap / plug is rated minimum 250 V, 16 A, that it has a connection to ground / earth and that it has an integral cable grip. Follow the cord cap / plug manufacturer's assembly instructions.

If you need to install a Neutrik powerCON TRUE1 connector on a power cable, follow the instructions given in the Support area of the Neutrik website at [www.neutrik.com](http://www.neutrik.com).



Respect the color coding used in the supplied power cable and in your local mains power wiring system. US and EU systems use the color coding shown below:

	Live or L	Neutral or N	Ground / Earth or 
<b>US system</b>	Black	White	Green
<b>EU system</b>	Brown	Blue	Yellow/green

### Connecting multiple fixtures to power in a chain

You can connect fixtures to power in a daisy-chain to simplify your power circuit layout.



**Warning!** Do not connect more than two (2) KNV fixtures in total to power in one chain at 100-120 V, 60 Hz. Do not connect more than four (4) KNV fixtures in total to power in one chain at 200-240 V, 50 Hz.

The power input cable supplied with the fixture is rated 16 A maximum. Add together the maximum current draw ratings of all the devices that you intend to connect to power in a daisy chain and do not create a chain with a total maximum current draw of more than 16 A, or you will create a risk of fire and electric shock.

To connect fixtures to power in a chain:

1. Obtain power relay cables that have male and female Neutrik powerCON TRUE1 connectors. Cables must be minimum 14 AWG or 1.5mm<sup>2</sup>, rated minimum 16 A and suitable for the environment and application.
2. Connect the power input cable to the Mains IN socket of the first fixture.
3. Connect a relay cable to the Mains OUT / THRU socket of the first fixture and to the Mains IN socket of the second fixture.
4. If you are using 100-120 V, 60 Hz AC mains power, do not connect any devices to the Mains OUT / THRU socket of the second fixture. If you are using 200-240 V, 50 Hz AC mains power, you may connect a maximum of two more fixtures Mains OUT to Mains IN so that the chain contains a maximum of four fixtures in total.

## **8. Connecting to control data**

Check that all cables and connectors are suitable for the installation environment and application (see recommendations in 'Avoiding damage to the fixture' on page 11).

Keep connectors sealed with their rubber caps at all times when not in use.

Use CAT6 or better Ethernet cables for the data link.

The KNV has two EtherCON sockets for in and thru connections to a DMX data link. It makes no difference which socket you use for data in and which for data thru. KNV fixtures support USITT DMX 512A, Art-Net and sACN signal protocols. They also support RDM (Remote Device Management).

If you would like advice with planning and installing a DMX link, your GLP supplier will be happy to provide assistance.

## 9. Starting and stopping operation



**Warning!** Before you apply power to the fixture or operate it after a blackout, make sure that nobody is looking directly into the front of the fixture.

The KNV's TRUE1 AC mains power input connector supports hot-plugging, and it can be quickest to disconnect a live power cable if you need to shut down power urgently, but it is still good practice to shut down power to the AC mains power circuit before connecting and disconnecting power cables.

To start operation, check that nobody is looking into the front of the fixture, then apply power to the AC mains power circuit.

To stop operation, shut down power to the AC mains power circuit.

### Transportation and storage

We strongly recommend that you transport the KNV either in a flightcase or in its original packaging to protect it from damage during transportation. The product warranty does not cover damage caused by abnormal shocks during transportation and handling.

When the fixture is not installed, disconnect it from power and store it in a dry location.

## 10. Cleaning and maintenance



**Warning!** There are no user-serviceable parts inside the fixture. Opening the fixture can compromise its IP54 rating and cause damage that is not covered by the product warranty. Any service operation that requires removal of a cover must be performed by a professional service technician with the tools, skills, and personal protective equipment to maintain high-powered lighting equipment safely and efficiently.

### Cleaning

KNV fixtures require occasional cleaning to prevent the buildup of dust, dirt, and residue from atmospheric effects. Pay special attention to the air vents and the front of the fixture. Failure to keep the fixture clean will significantly reduce light output and may cause damage that is not covered by the product warranty. Regular cleaning will ensure maximum performance and reliable operation.

You can clean the front of the fixture using a soft cloth slightly dampened with a household or automotive glass cleaning product.

You can clean the air vents on the back of the fixture with a soft brush and vacuum cleaner. Never apply strong compressed air or a strong vacuum to a cooling fan. You may spin the fan too fast and cause damage.

The cleaning schedule depends on the operating environment. The intervals below are suggestions from our experience with typical installations. Adjust as necessary.

Maintenance task	Interval	Materials
Clean front of fixture	Weekly	Soft cloth dampened with glass-cleaning fluid
Clean fans and air channels	Monthly	Vacuum cleaner, compressed air, etc.

### GLP Service and Support

Contact information for the nearest GLP Service and Support is available online at [www.glp.de/en/service](http://www.glp.de/en/service), by email at [info@glp.de](mailto:info@glp.de), or by telephone at the following numbers:

- GLP Germany: +49 (7248) 927 19-55
- GLP N. America: +1 818 767-8899
- GLP UK: +44 1392 690140
- GLP Asia: +852 (3151) 7730
- GLP Nordic: +46 737 57 11 40

## 11. Technical specifications

### Light source

#### **White LEDs**

LED power: 30 W  
Number of LEDs: 25  
Color temperature: 5000 K  
CRI: >80  
Lifetime: 50 000 hrs. to > 70% luminous output

#### **RGB LEDs**

LED power: 0.25 W  
Number of LEDs: 400  
Lifetime: 50 000 hrs. to > 70% luminous output

### Optics

Total output: 55 030 Lumens

#### **White LEDs**

Beam angle: 120°

#### **RGB LEDs**

Beam angle: 120 °

### Effects

Color mixing: RGB, RGBW, continuously variable, 8 and 16-bit  
Shutter/strobe: White and RGB strobes with pulse, flare and continuous output effects  
Strobe control: Adjustable flash intensity, rate (max. 16.67 Hz) and duration,  
Dimmer: 0-100% continuous, two dimming curve options  
Multilayer FX engine with multiple fixture synchronization options  
Color temperature correction: 2500 K – 10 000 K, electronic, adjustable via RGBW

### Control

Control system: USITT DMX512  
Control protocols: DMX, ArtNet, sACN  
RDM compliance: ANSI/ESTA E1.20  
DMX channel footprint: 10 / 23 / 40 / 86 / 35/ 102 / 202 depending on mode  
Pixel mapping options: 25 x white pixels, 25 x RGB pixels, 25 x RGBW pixels  
Onboard interface: Battery-powered control panel with backlit LCD graphic display  
Transceiver: RS-485  
Receiver: Opto-isolated RS-485  
Setting and addressing: Onboard control panel / via Ethernet data link / RDM  
Fixture software updates: Via EtherCON socket

## Construction

Color: Black  
Housing main shell: Steel  
Ingress protection rating: IP54

## Installation

Operating position: Any  
Minimum distance to combustible materials: 0.2 m (8 in.)  
Minimum distance to illuminated surfaces: 1.0 m (39.4 in.)  
Installation environment: Temporary or permanent Indoor installation, temporary outdoor installation (IP54)  
Secondary attachment point: Eyelet for safety cable on fixture

### **Mounting options**

Cube: Free-standing on horizontal surface, suspended vertically or fastened to surface or structure  
Arc: Suspended vertically or fastened to surface or structure

### **Installation hardware**

Mechanical Interconnection Bracket (supplied with fixture)  
Adjustable Floorstand-Bracket (supplied with fixture): Can support one KNV Cube suspended vertically, can be used as floorstand for KNV Cube  
Installation Bracket: Can support up to four KNV Cube fixtures suspended vertically from rigging clamp or support creative combinations of Cube and/or Arc fixtures.  
Mechanical connection plates for fixture alignment in multiple Cube and Arc arrays

## Connections

AC mains power in and thru (out): Neutrik powerCON TRUE1 with sealing cap  
Control data in and thru (out): EtherCON with sealing cap  
Fixture software update: Over data link

## Construction

Ingress protection rating: IP54  
Effective projected area, KNV Cube: 0.0625 m<sup>2</sup>  
Effective projected area, KNV Arc: 0.0736 m<sup>2</sup>  
Fixture housing: Steel  
Color: Black

## Electrical

AC mains power: 100-240 V nominal, 50/60 Hz  
Power supply unit: Auto-ranging electronic switch mode  
Equivalent leakage current: 1.11 mA  
Specific power factor (SPF): 0.9543  
Minimum power consumption, zero output: <45 W  
Maximum power consumption, all LEDs at 100% output: 800 W

**Maximum permitted number of fixtures daisy-chained to power**

2 x KNV total @ 100-120 V, 60 Hz

4 x KNV total @ 200-240 V, 50 Hz

**Included items**

US power cable: 16 A, 14 AWG, UL-listed, E304117, SJT, 4.9 ft.

EU power cable: 16 A, 1.5 mm<sup>2</sup>, H05VV-F, 1.5 m

**Thermal**

Cooling: Combined convection and forced air (temperature-regulated)

Maximum surface temperature, housing: 65° C (149° F)

maximum surface temperature, front screen: 80° C (176° F)

Minimum ambient temperature: 0° C (32° F)

Maximum ambient temperature: 45° C (113° F)

Max. total heat dissipation (calculated): 2700 BTU/hr.

**Dimensions and weight**

**Cube, not including bracket**

Height: 250 mm (9.8 in.)

Width: 250 mm (9.8 in.)

Depth: 183 mm (7.2 in.)

Weight: 9.3 kg (20.5 lbs.)

**Cube, including KNV Floorstand-Bracket**

Height: 293 mm (11.6 in.)

Max. height with fixture rotated: 318 mm (12.6 in.)

Width: 344 mm (13.6 in.)

Depth: 243 mm (9.6 in.)

Weight: 10.6 kg (23.4 lbs.)

**Cube, including KNV Installation Bracket**

Height: 268 mm (10.6 in.)

Width: 250 mm (9.8 in.)

Depth: 228 mm (9.0 in.)

Weight: 10.8 kg (23.9 lbs.)

**Arc, not including bracket**

Height: 250 mm (9.8 in.)

Width: 250 mm (9.8 in.)

Depth: 180 mm (7.1 in.)

Weight: 9.7 kg (21.4 lbs.)

**Arc, including KNV Installation Bracket**

Height: 268 mm (10.6 in.)

Width: 250 mm (9.8 in.)

Depth: 228 mm (9.0 in.)

Weight: 11.6 kg (25.6 lbs.)

## 12. Dimensions

### KNV Cube with KNV Installation Bracket

All dimensions are in millimeters

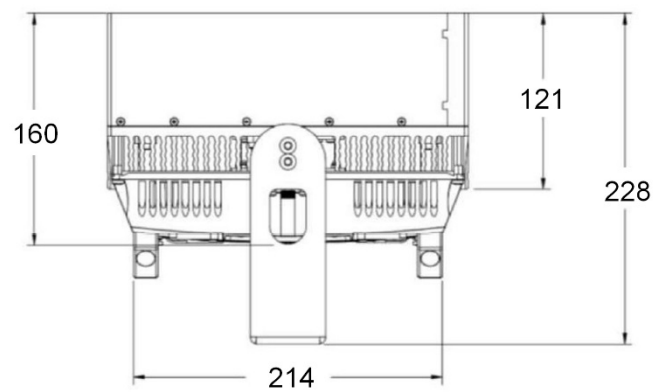
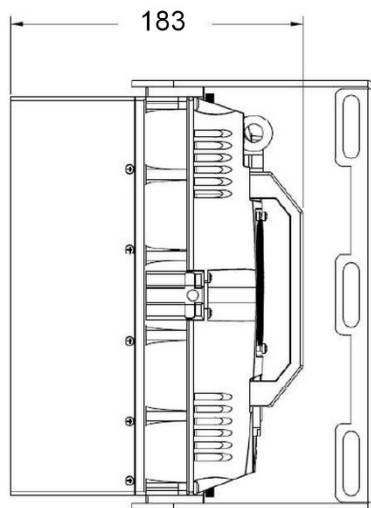
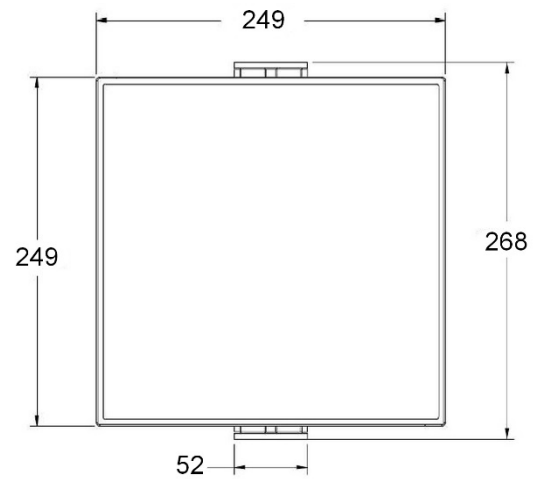



### KNV Cube with KNV Floorstand-Bracket

All dimensions are in millimeters

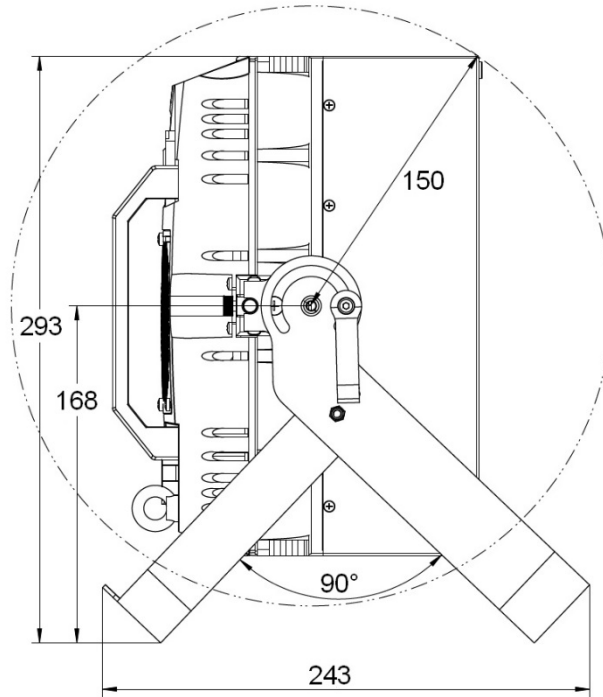

### KNV Arc

All dimensions are in millimeters

Fixture shown with KNV Installation Bracket installed

