

INSTRUCTION MANUAL

PRELIMINARY

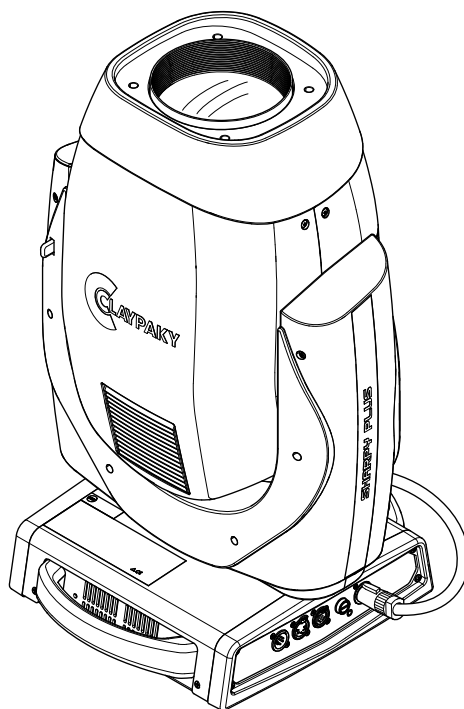

INDEX

Page	Contents
2	1. Safety information
3	2. Unpacking and preparation
4	3. Installation and start-up
4	3.1 Installing the fixture
4	3.2 Connecting to mains supply
5	3.3 Connecting the control signal line: DMX / Art-Net
5	3.4 Switching on the fixture and basic SetUp
7	4. Maintenance
7	4.1 Opening the covers
8	4.2 Periodical cleaning
9	4.3 Effects module removal
10	4.4 Cleaning of the filters
12	4.5 Rotating gobos
13	4.6 Battery removal
14	5. Specifications

Congratulations on choosing a Claypaky product!

We thank you for your custom.

Please note that this product, as all the others in the rich Claypaky range, has been designed and made with total quality to ensure excellent performance and best meet your expectations and requirements.

1. SAFETY INFORMATION

EN

SAFETY INFORMATION

IMPORTANT: Claypaky recommends you carefully read and keep the safety information on this product, also available in digital format at the following link:

www.claypaky.com

Ref: [FIS01H: Safety information Sharpy Plus]

IT

INFORMAZIONI DI SICUREZZA

IMPORTANTE: Claypaky raccomanda di leggere accuratamente e conservare le informazioni di sicurezza relative a questo prodotto, sempre reperibili in versione digitale al seguente link:

www.claypaky.com

Rif: [FIS01H: Safety information Sharpy Plus]

DE

INFORMATIONEN ZUR SICHERHEIT

WICHTIG: Claypaky empfiehlt, die Sicherheitsinformationen bezüglich dieses Produkts genau zu lesen und aufzubewahren. Sie sind in Digitalversion immer unter folgendem Link auffindbar:

www.claypaky.com

Ref: [FIS01H: Safety information Sharpy Plus]

ES

INFORMACIONES DE SEGURIDAD

IMPORTANTE: Claypaky recomienda leer detenidamente y conservar la información de seguridad relativa a este producto. Además, está disponible una versión digital de la misma en el siguiente enlace:

www.claypaky.com

Ref: [FIS01H: Safety information Sharpy Plus]

FR

CONSIGNES DE SÉCURITÉ

IMPORTANT: Claypaky recommande de lire attentivement et de conserver les informations de sécurité relatives à ce produit, disponibles en version digitale au lien suivant:

www.claypaky.com/download

Réf. : [FIS01H: Safety information Sharpy Plus]

RU

ИНСТРУКЦИЮ ПО ТЕХНИКЕ БЕЗОПАСНОСТИ

ВАЖНО: Claypaky рекомендует внимательно прочитать и сохранить инструкцию по технике безопасности данного изделия, которая всегда доступна в электронном формате по следующей ссылке:

www.claypaky.com

Наименование: [FIS01H: Safety information Sharpy Plus]

2. UNPACKING AND PREPARATION

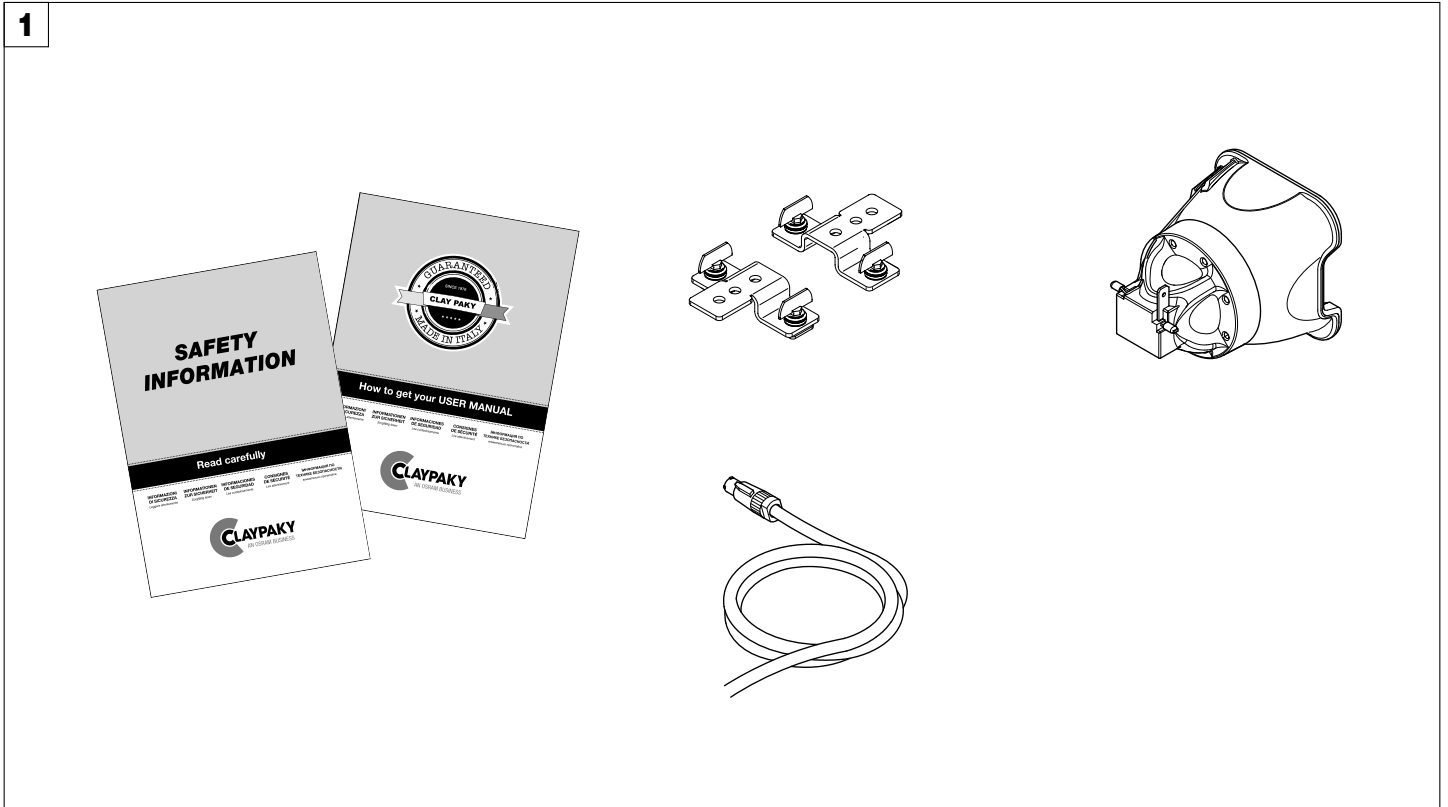

Packing contents - Fig. 1

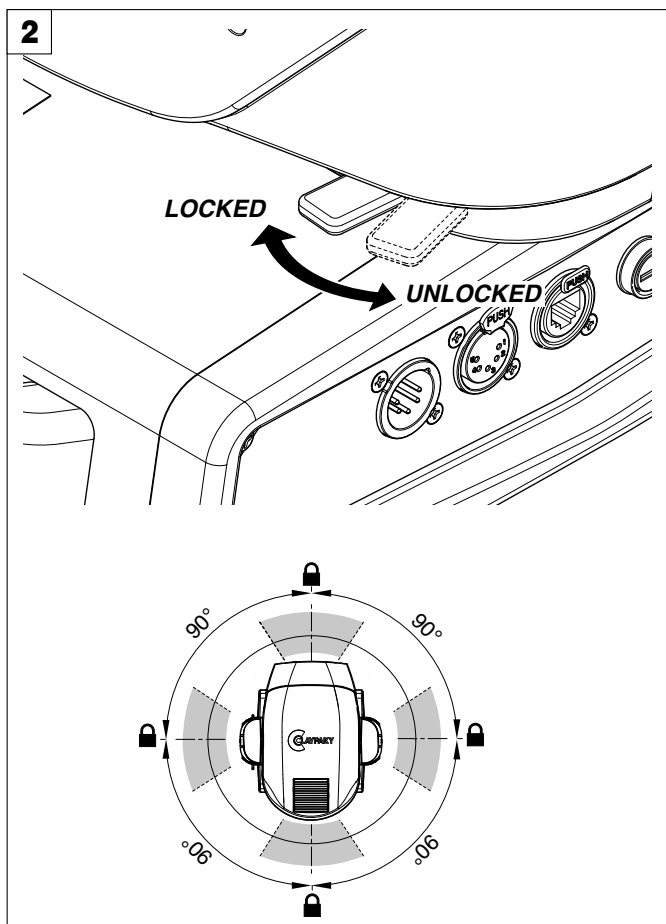

PAN Mechanism Lock and Release (every 90°) - Fig. 2

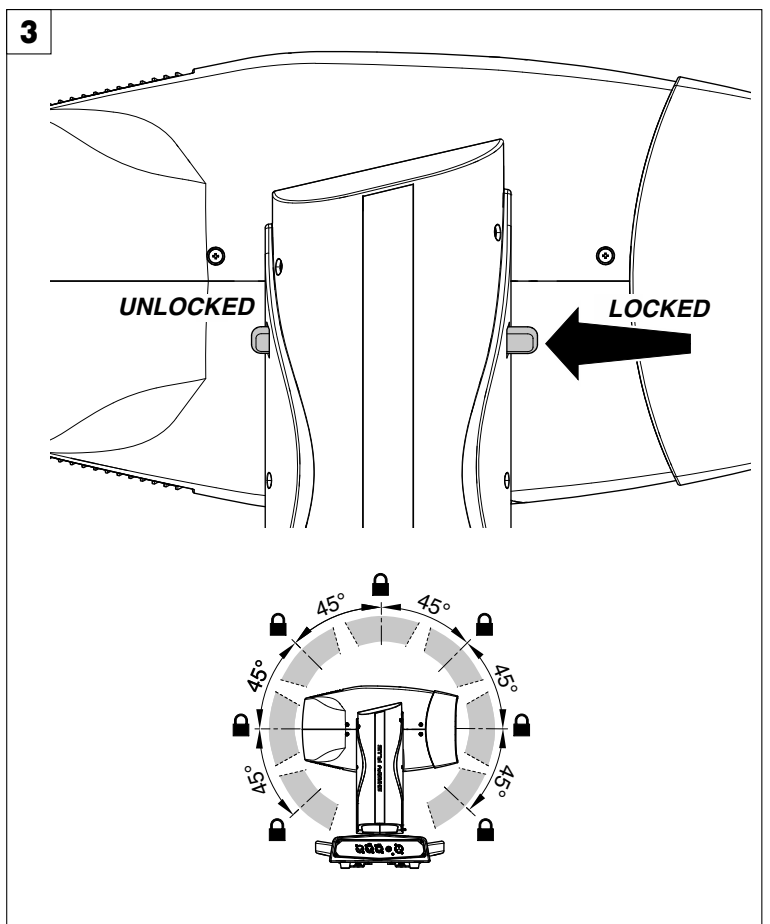

TILT Mechanism Lock and Release (every 45°) - Fig. 3

3. INSTALLATION AND START-UP

3.1 Installing the fixture

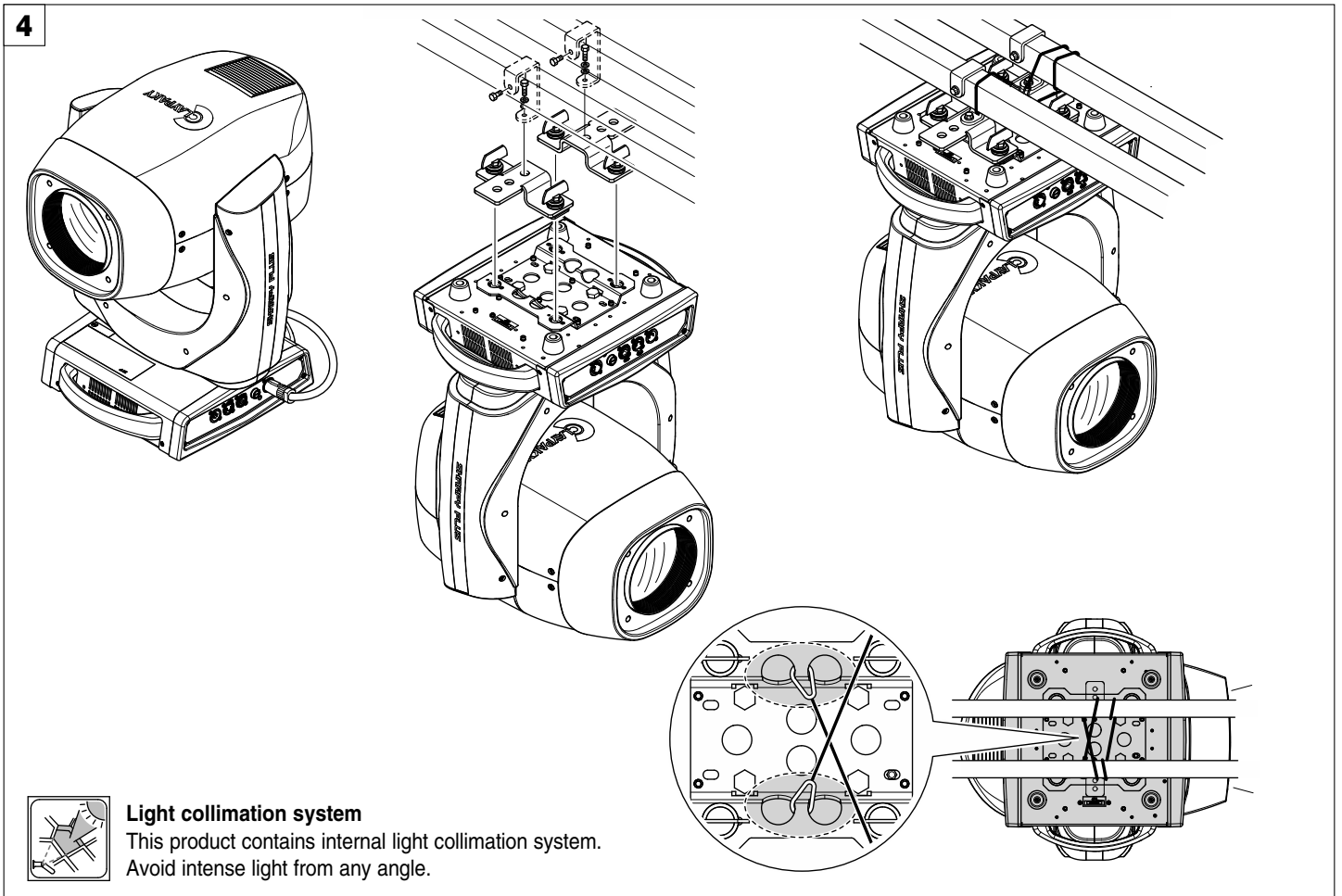

Installing the projector - Fig. 4

The projector can be installed on the floor resting on special rubber feet, on a truss or on the ceiling or wall.

WARNING: with the exception of when the projector is positioned on the floor, the safety cable must be fitted. (Cod. 105041/003 available on request). This must be securely fixed to the support structure of the projector and then connected to the fixing point at the centre of the base.

3.2 Connecting to mains supply

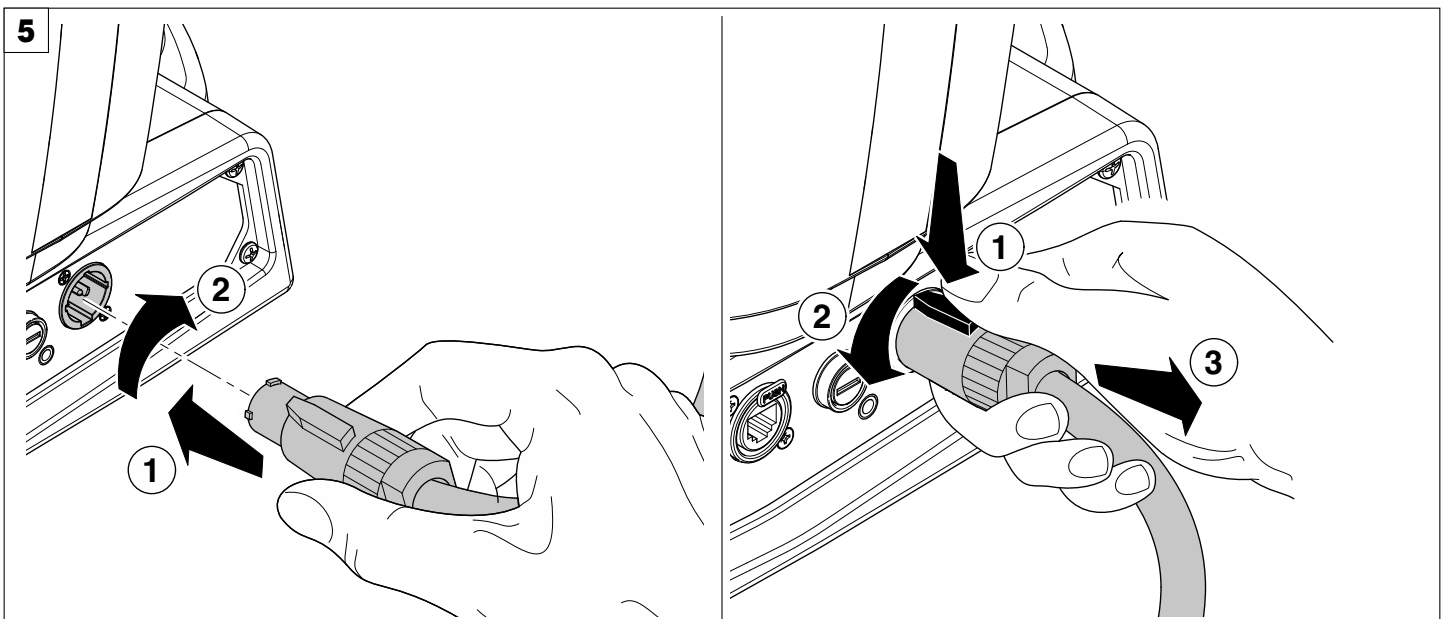

Connecting and disconnecting power cable - Fig. 5

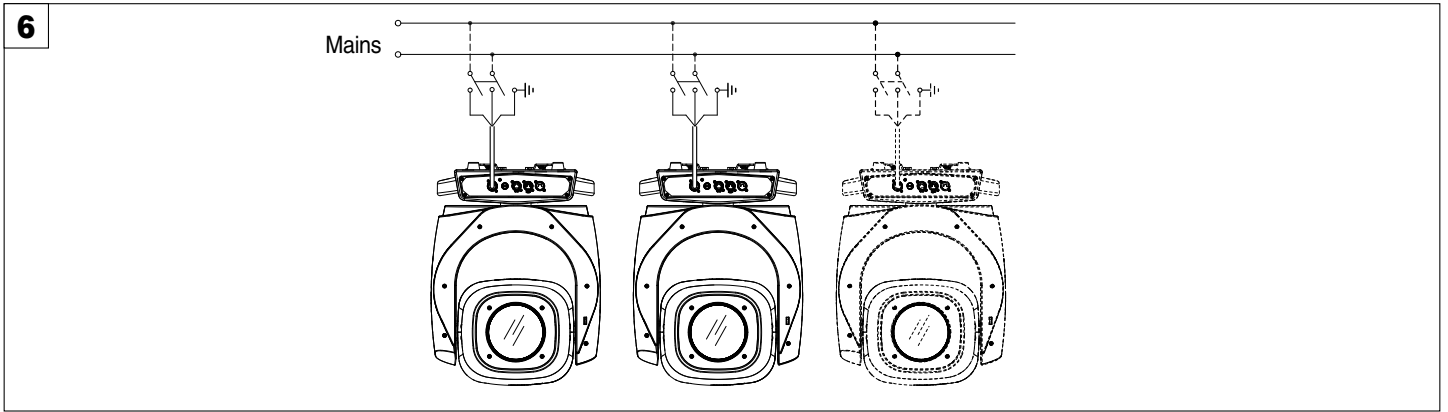

Connecting to the mains supply - Fig. 6

3.3 Connecting the control signal line: DMX / Art-Net

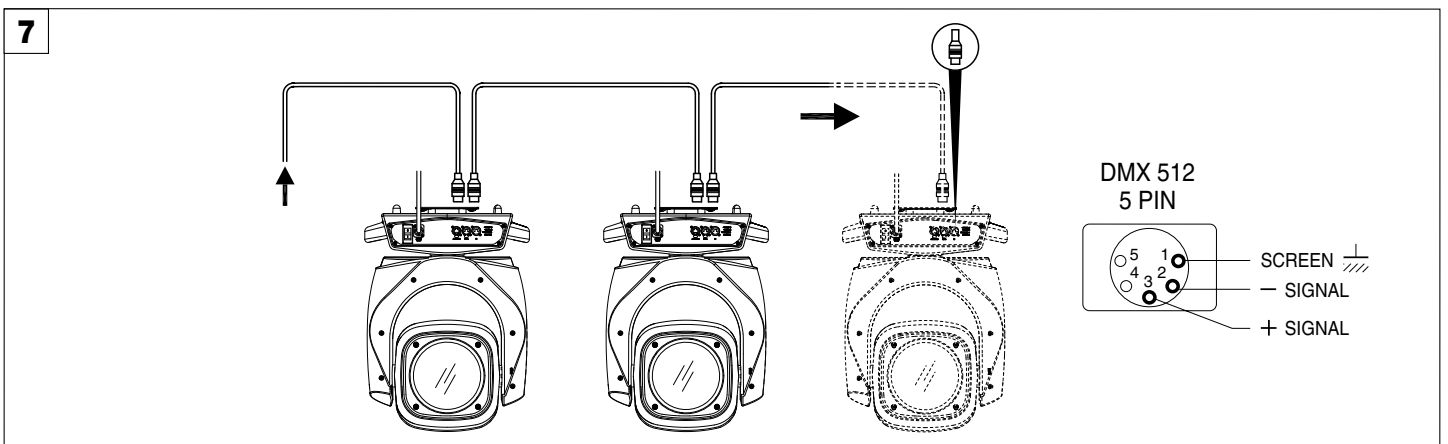

Connecting to the control signal line (DMX) - Fig. 7

Use a cable conforming to specifications EIA RS-485: 2-pole twisted, shielded, 120Ohm characteristic impedance, 22-24 AWG, low capacity. Do not use microphone cable or other cable with characteristics differing from those specified. The end connections must be made using XLR type 5-pin male/female connectors. A terminating plug must be inserted into the last projector with a resistance of 120Ohm (minimum 1/4 W) between terminals 2 and 3.

IMPORTANT: The wires must not make contact with each other or with the metal casing of the connectors. The casing itself must be connected to the shield braid and to pin 1 of the connectors.

3.4 Switching on the fixture and basic SetUp

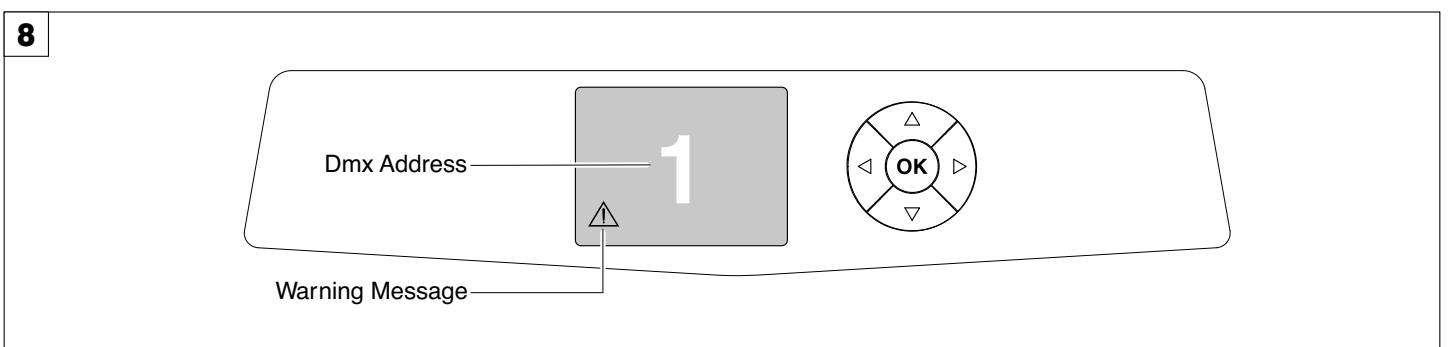

Switching on the projector - Fig. 8

Press the switch. The projector starts resetting the effects. At the same time, the following information scrolls on the display:



	Model SHARPY PLUS	Firmware Version X.X.X Date - Hour	xxx (Fixture ID) Dmx Address xxx	System errors E: W:
--	-----------------------------	------------------------------------------	-------------------------------------	---------------------------------------

On conclusion of resetting in case of absence of the dmX signal, Pan and Tilt move to the "Home" position (Pan 128 bit - Tilt 128 bit). The control panel (Fig. 8) has a display and buttons for the complete programming and management of the projector menu. The display can be in one of two conditions: rest status and setting status. When it is in the rest status, the display shows the projector's DMX address.

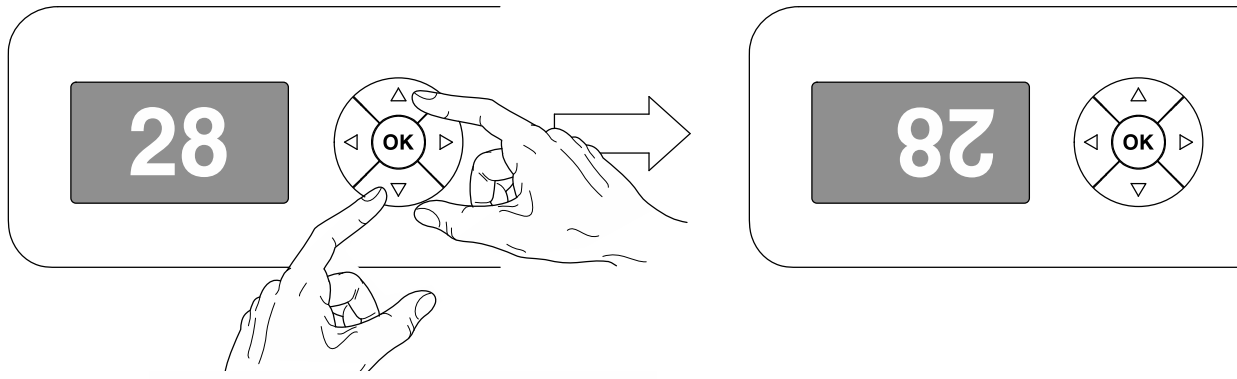
During menu setting status, after a wait time (about 30 seconds) without any key having been pressed, the display automatically returns to rest status. It should be noted that when this condition occurs, any possible value that has been modified but not yet confirmed with the **OK** key will be cancelled.



Reversal of the display - Fig. 9

To activate this function, press UP  and DOWN  keys simultaneously while the display is in the rest mode. This status will be memorised and maintained even for the next time it will be switched on. To return to the initial state, repeat the operation all over again.

Setting the projector starting address

On each projector, the starting address must be set for the control signal (addresses from 1 to 512).

The address can also be set with the projector switched off.

If there is no DMX input signal, the display will show "No signal".

Functions of the buttons - Using the menu

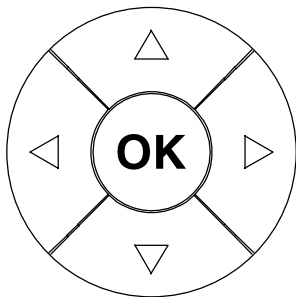

Confirms the displayed value, or activates the displayed function, or enters the successive menu.



DOWN

Decreases the value displayed (with auto-repetitions) or passes to the next item in the menu.



UP

Increases the value displayed (with auto-repetitions) or passes to the previous item in a menu.



LEFT







Return to the top level



RIGHT

Commute from units, tens, hundreds, in the "Address" and "Calibration" menu.

USING THE MENU:

- 1) Press LEFT  once – "Main Menu" appears on the display.
- 2) Use the UP  and DOWN  keys to select the menu to be used:
 - Setup (Setup Menu): To set the setting options.
 - Option (Option Menu): To set the operating options
 - Informations (Informations Menu): To read the counters, software version and other information.
 - Manual Control (Manual control Menu): To trigger the test and manual control functions.
 - Test (Test Menu): To check the proper functioning of effects
 - Advanced (Advanced Menu): Access to the "Advanced menu" is recommended for a trained technical personnel.
- 3) Press  to display the first item in the selected menu.
- 4) Use the UP  and DOWN  keys to select the MENU items.

Setting addresses and options with the projector disconnected

The projector's DMX address, as well as other possible operating options, can also be set when the appliance is disconnected from the electricity supply. All that is needed is to press RIGHT  to momentarily activate the display and thus access the settings. Once the required operations have been carried out, the display will switch off again after a wait time of 30 seconds.

4. MAINTENANCE

4.1 Opening the covers

10

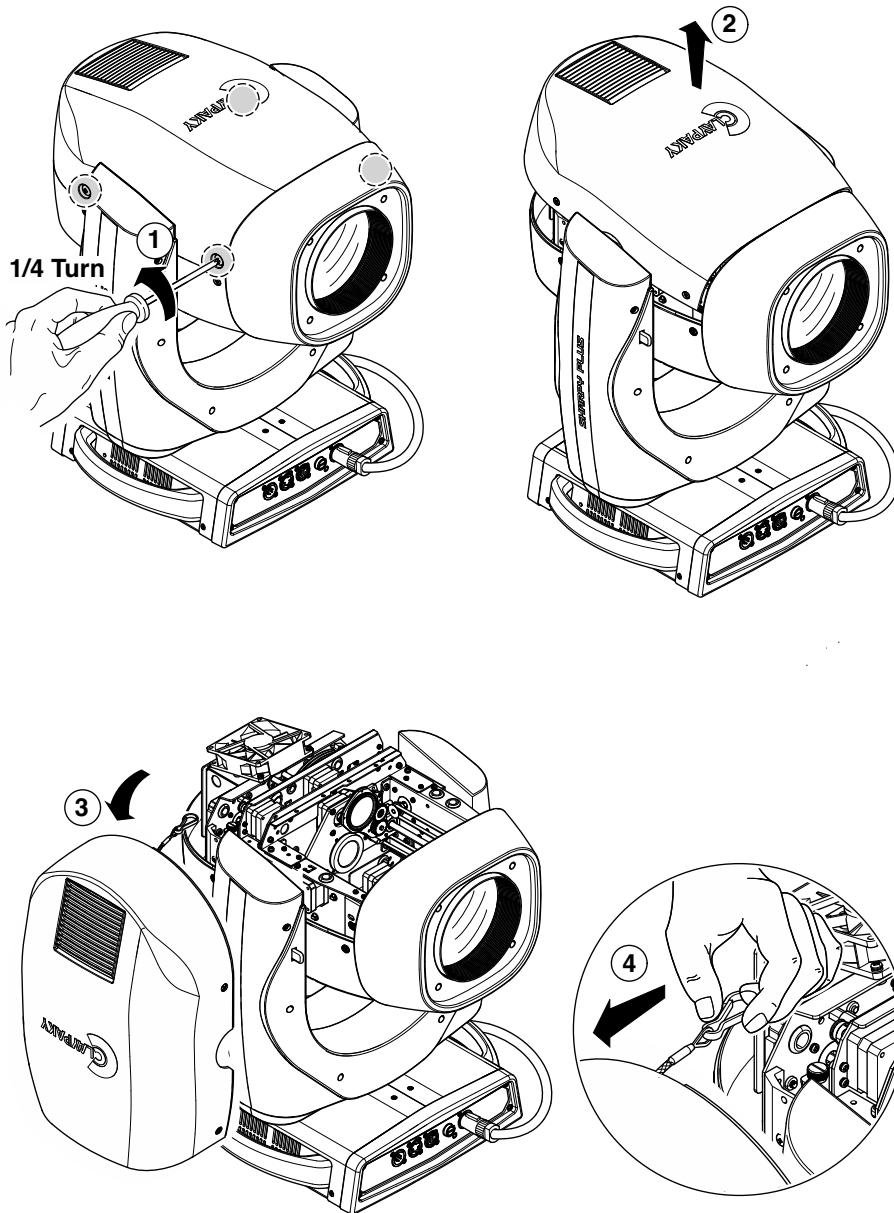

11

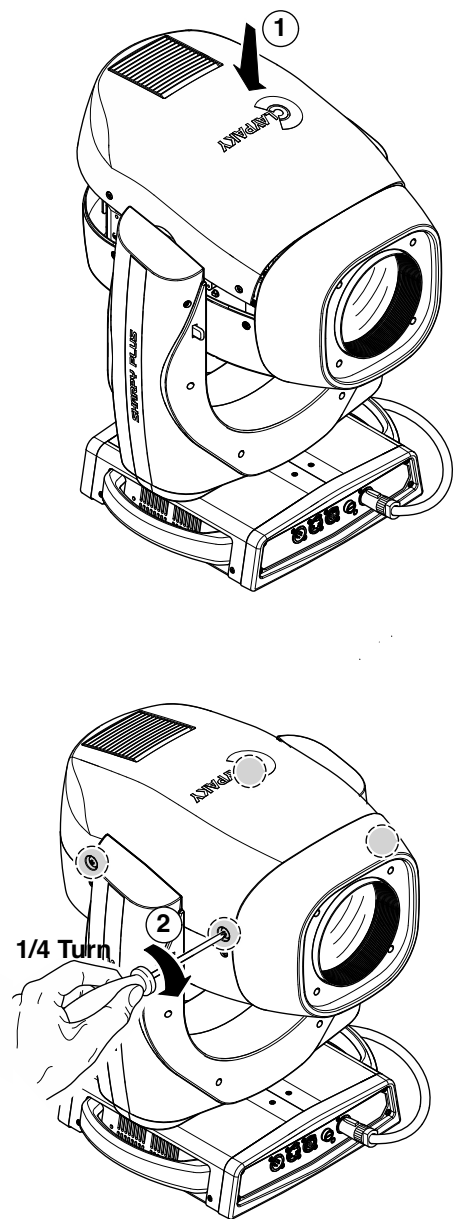

Locking and releasing Pan and Tilt movements - Refer to the instructions in the UNPACKING AND PREPARATION section.
Opening the head covers - Fig. 10.

Closing the head covers - Fig. 11.

4.2 Periodical cleaning

12

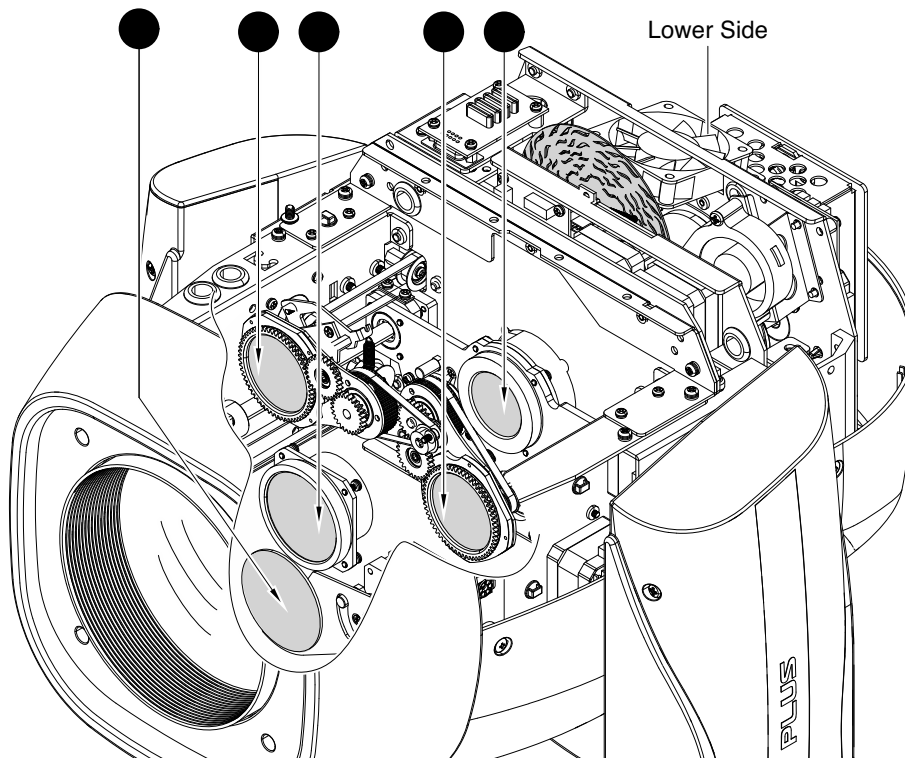
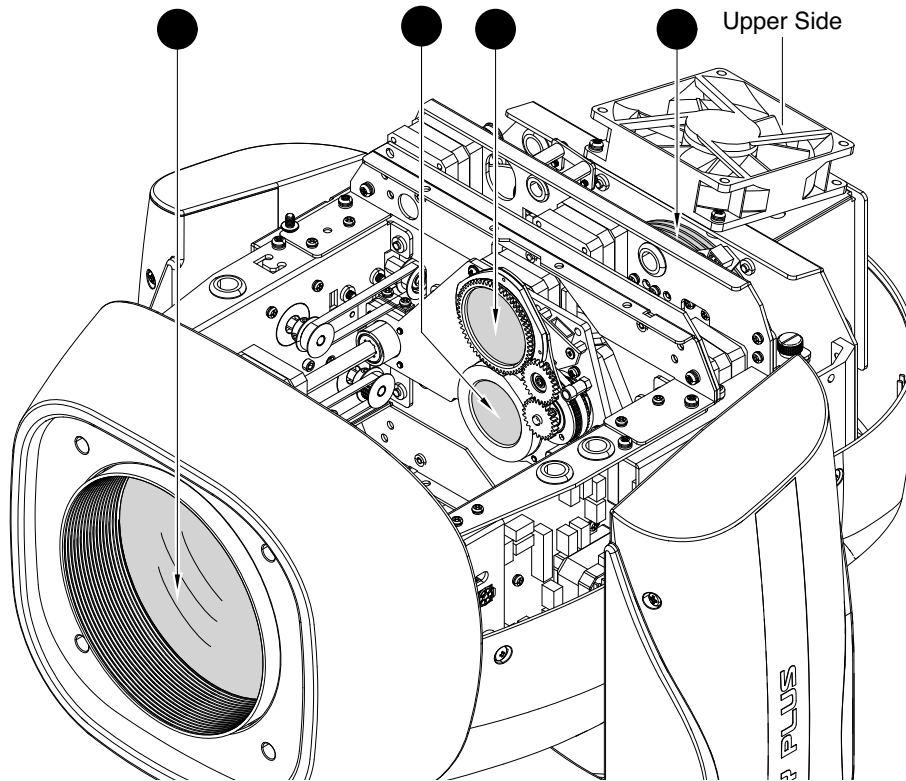

Periodical cleaning - Fig. 12

To ensure optimal operation and performance for a long time it is essential to periodically clean the parts subject to dust and grease deposits. The frequency with which the following operations are to be carried out depends on various factors, such as the amount of the effects and the quality of the working environment (air humidity, presence of dust, salinity, etc.).

Use a soft cloth dampened with any detergent liquid for cleaning glass to remove the dirt from the reflectors, from the lenses and filters. It is recommended that the projector undergoes an annual service by a qualified technician for special maintenance involving at least the following operations:

- General cleaning of internal parts.
- Restoring lubrication of all parts subject to friction, using lubricants specifically supplied by Claypaky.
- General visual check of the internal components, cabling, mechanical parts, etc.
- Electrical, photometric and functional checks; eventual repairs.

NOTE: keep a careful cleaning of the "CMY/colour filters assembly" to prevent rapid deterioration.

4.3 Effects module removal

13

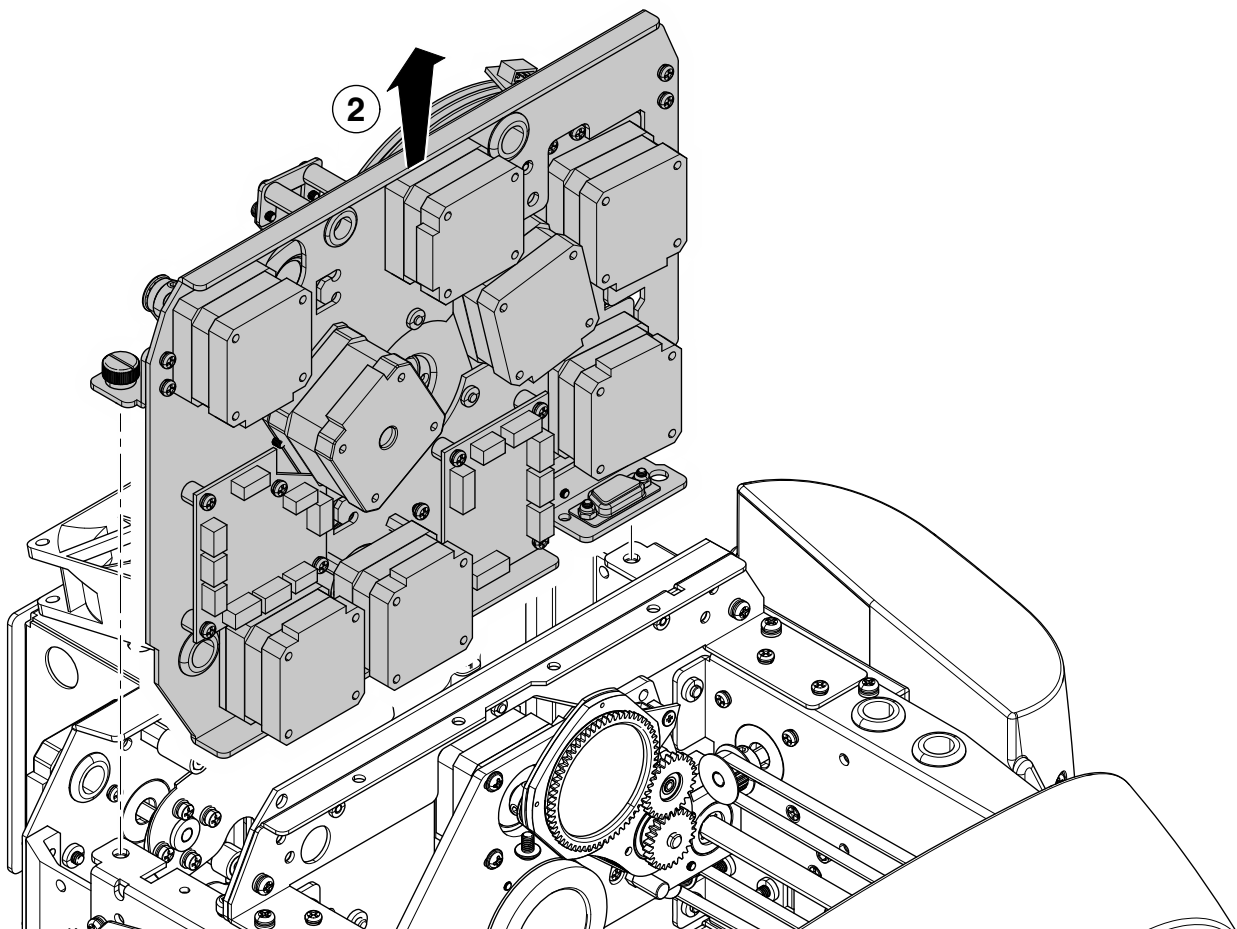
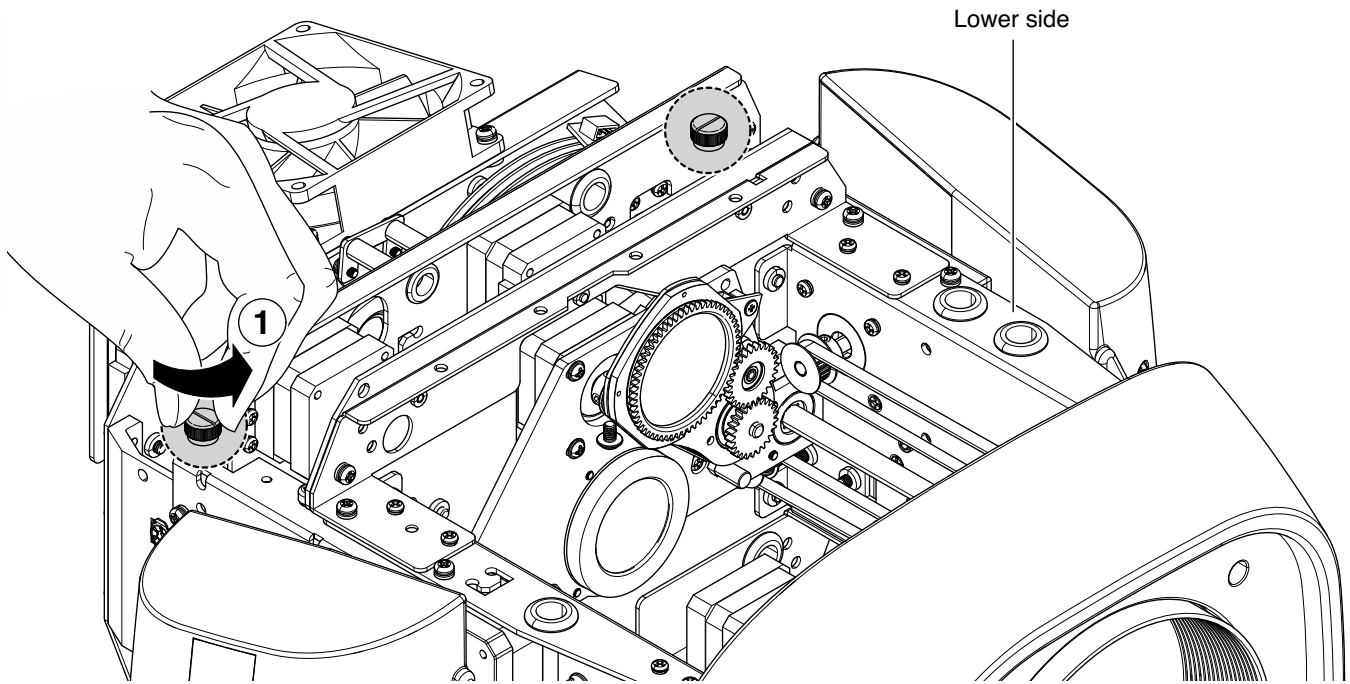

Extraction of the effect modules - Fig. 13.

IMPORTANT: Grasp the modules using the support structure and not the details which could get damaged.

Insertion of the effect modules: Repeat the operations indicated in Fig. 13, 14 and 15 in reverse order.

NOTE:

- Do not disconnect wiring harnesses when the fixtures is switched-on, to avoid to damage electronic boards.
- Do not switch-on the fixtures with wiring harness disconnected.

4.4 - Cleaning of the filters

13

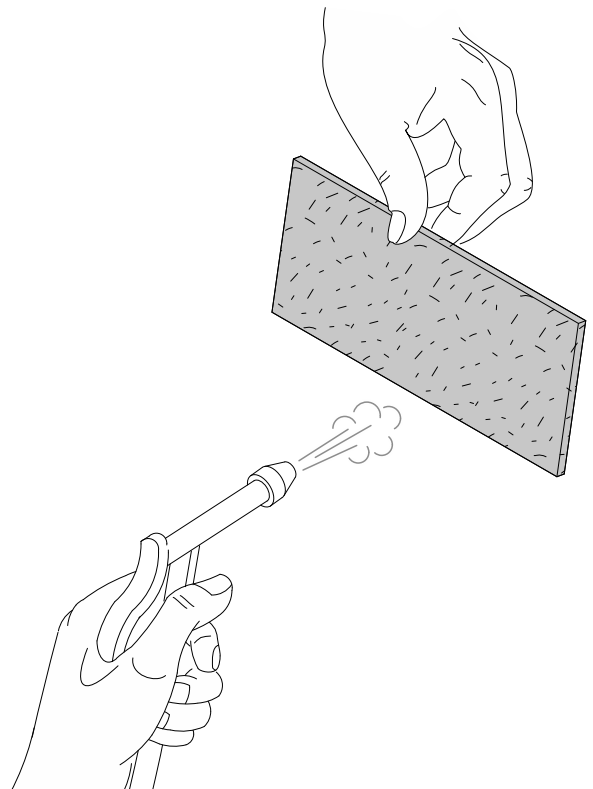
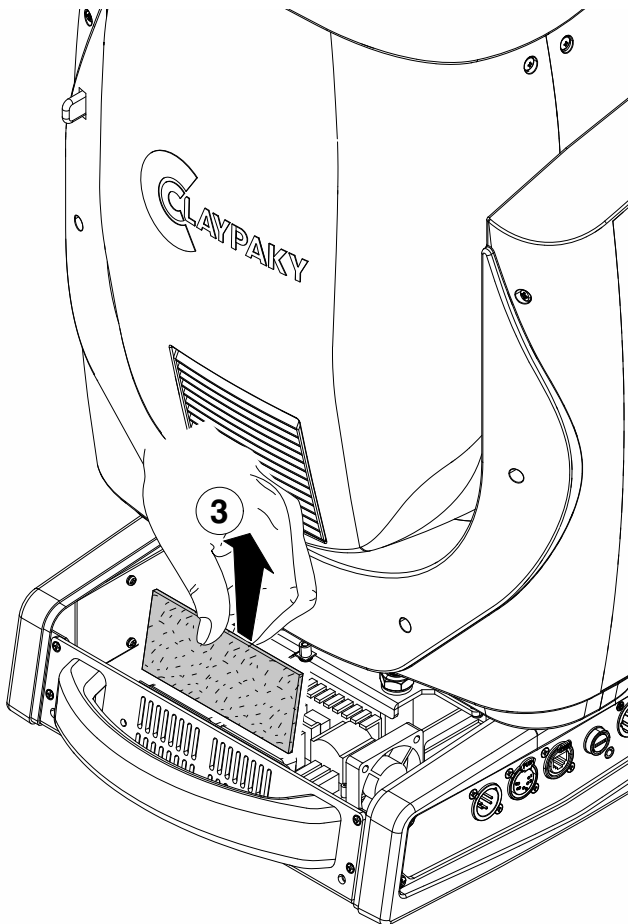
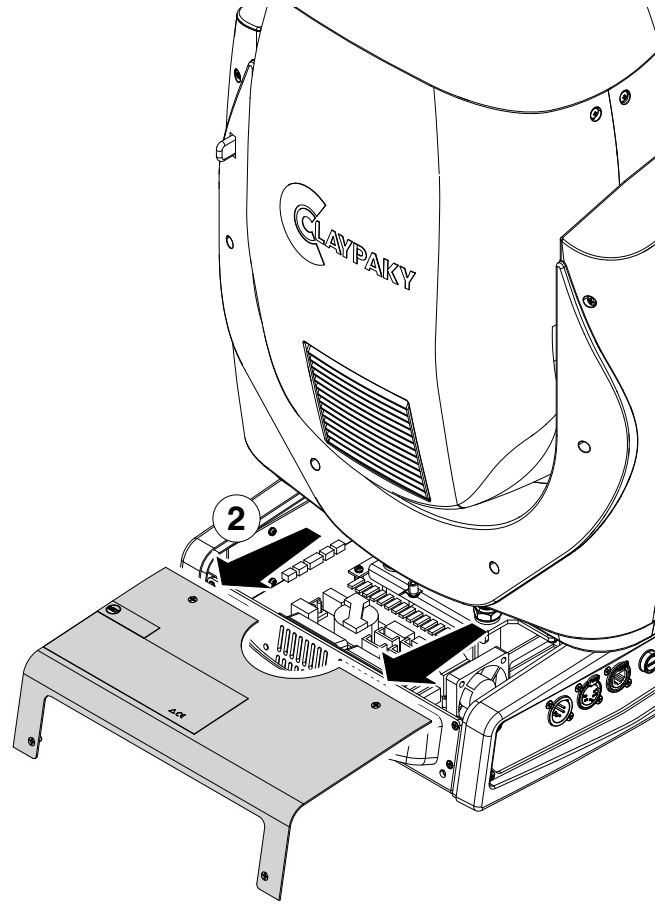
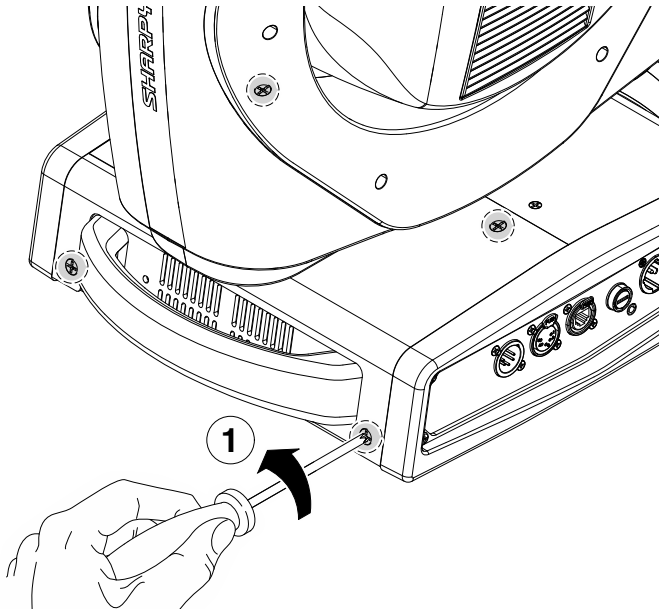
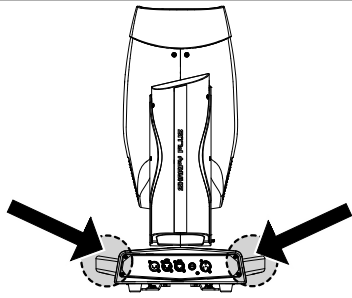

Cleaning of the filters - Fig. 13.

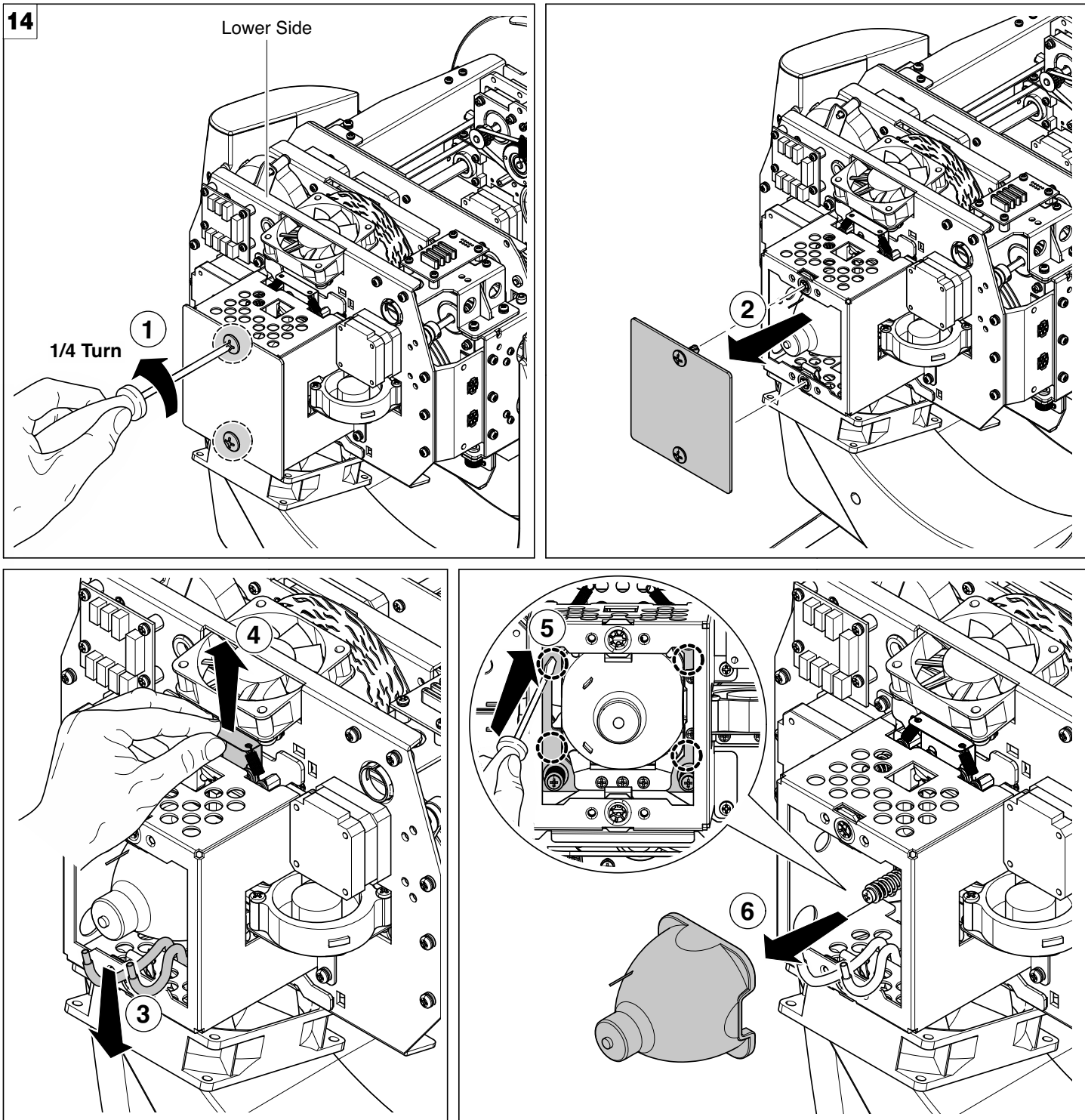

Lamp change - Fig 14.

Take the new lamp out of its package and insert in the fitting.

WARNING: *do not touch the lamp's envelope with bare hands. Should this happen, clean the bulb with a cloth soaked in alcohol and dry it with a clean, dry cloth.*

Lamp regulation

To centre the lamp, move the lamp holder as shown in the figure.

WARNING: *The lamp must be adjusted with the projector switched off. After adjusting, close the effects covers, switch on the projector and check that the adjustment has been correctly made. If necessary, switch off the projector, remove the effects covers and repeat lamp adjustment.*

REMARK:

- Lifetime of the lamp will be influenced by the switching cycle.
- After a successful starting, attempt to keep the lamp burning for at least 15 minutes in order to complete the chemical cycle of the lamp to secure the lifetime.
- After switching-off the lamp wait at least 2 minutes before switching-on it again.

4.5 - Rotating gobos

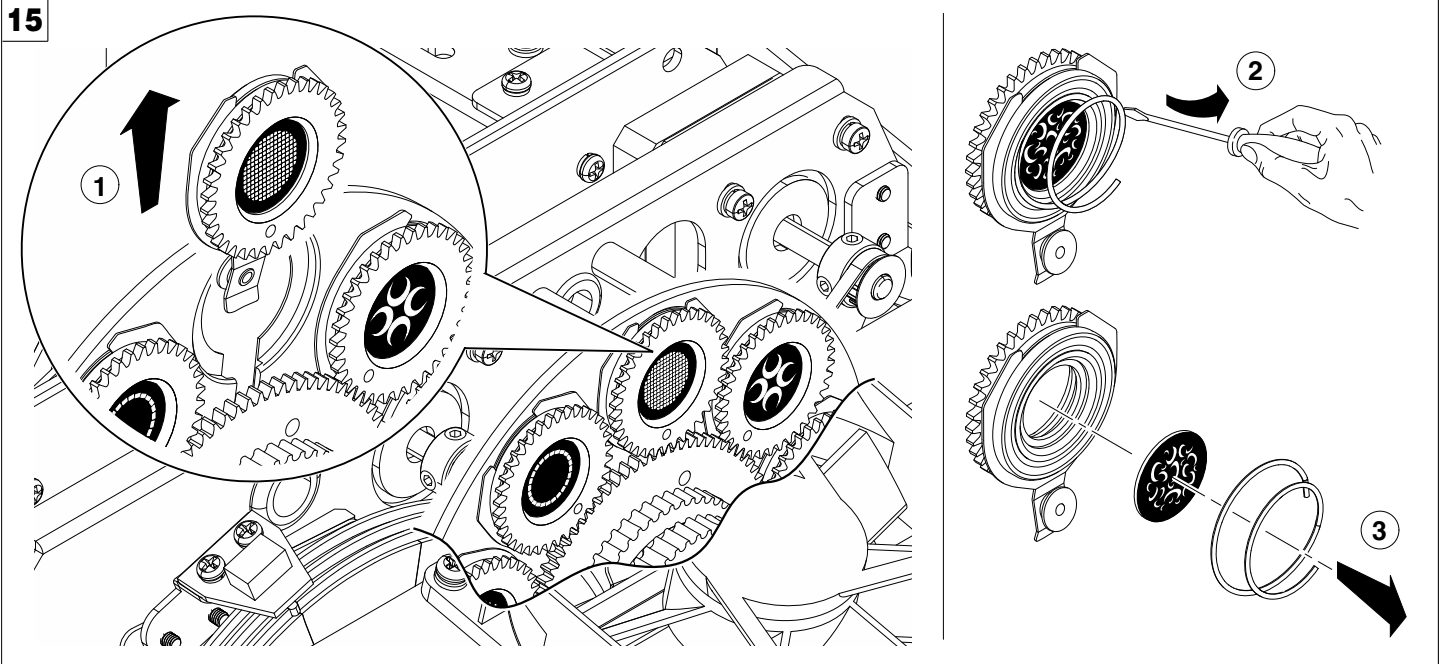

Bearing group replacement - Fig. 15

16 COATED GLASS GOBOS

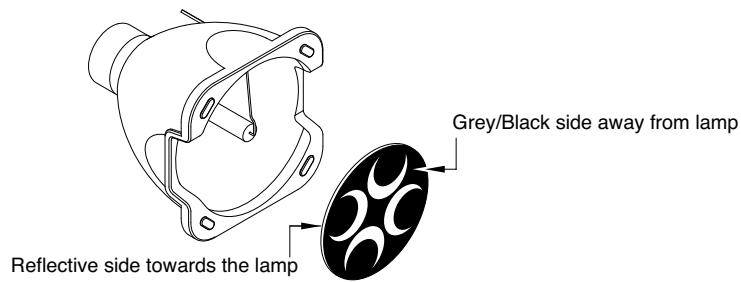

Gobo orientation - Fig. 16

The pictures shown the correct gobos orientation.

17 ROTATING GOBO

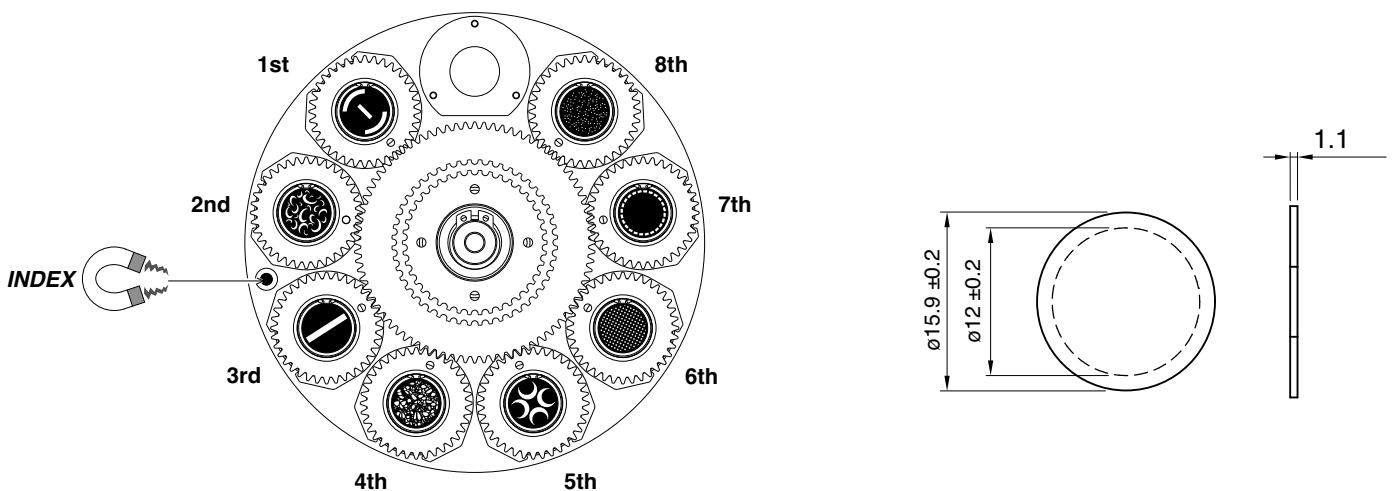

Replacing rotating gobos - Fig. 17

- Before use custom gobos contact Claypaky;
- The original gobos have a special coating designed specifically to resist to the high temperatures;
- The rotating gobo wheel only use dichroic glass gobos (it is not possible to use metal gobos);
- For more information contact Claypaky;

4.6 Battery removal

18

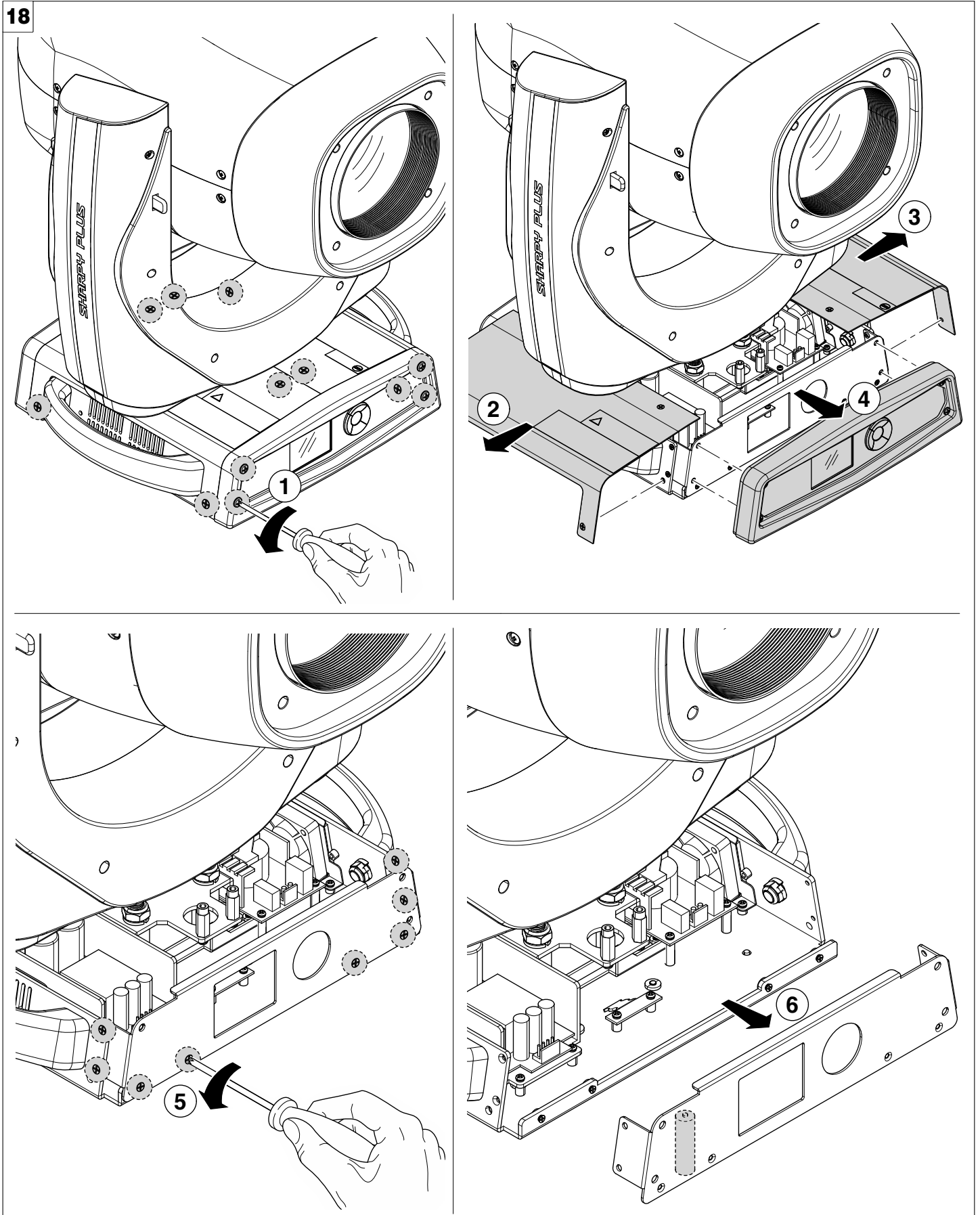

Battery removal - Fig. 18



This product contains a rechargeable battery. To preserve the environment, please dispose the battery at the end of its life according to the regulation in force.

5. SPECIFICATIONS

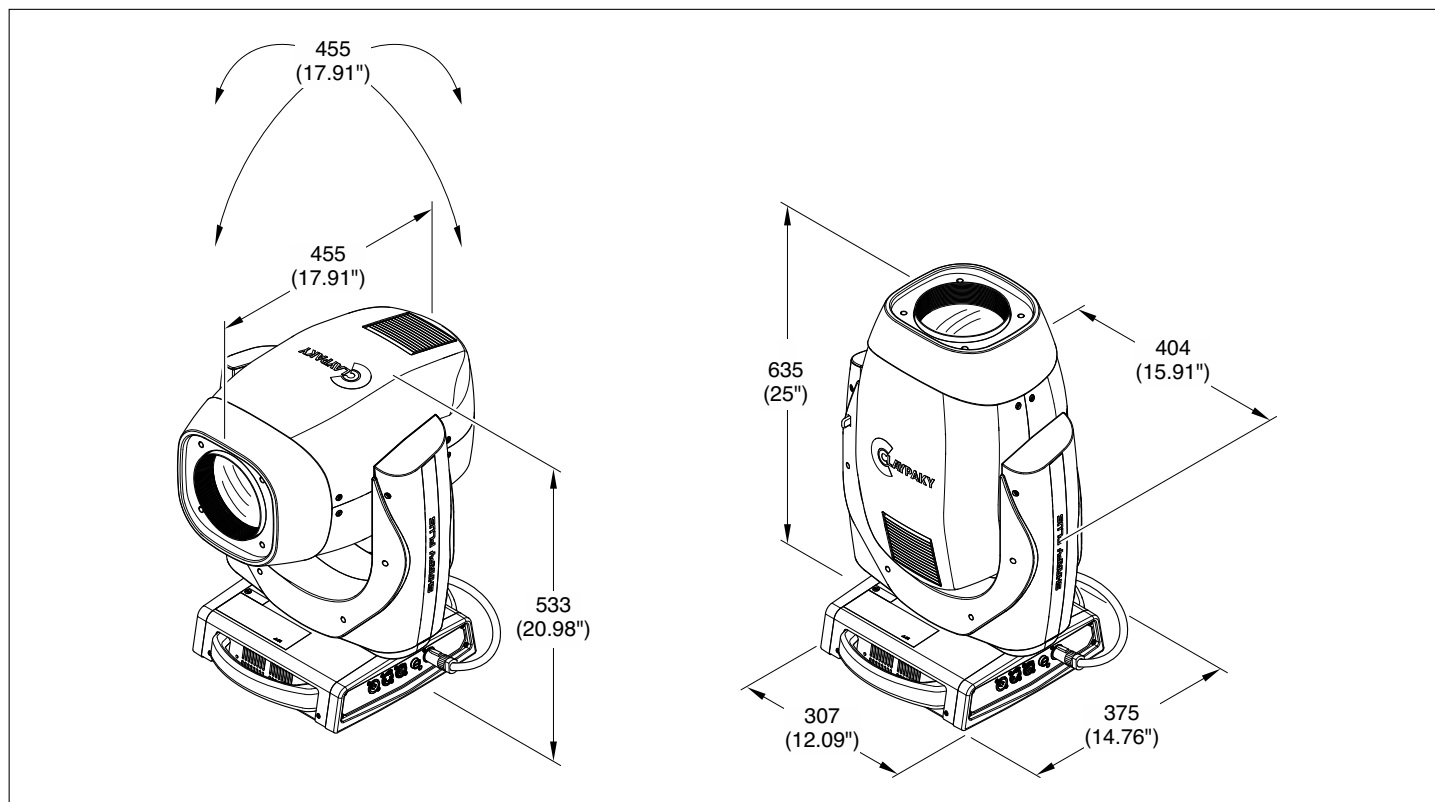

POWER SUPPLIES

AC power input Neutrik PowerCON True1 (IP65)
100-240V, 50/60 Hz

INPUT POWER

540 VA @230Vac - 50Hz

LIGHT SOURCE

Source: 330W X8 HRI Sirius Osram arc lamp

MOTORS

Stepper motors, operating with micro-steps, totally microprocessor controlled

CHANNELS

31 control channels

INPUTS

DMX 512 – Art-Net

IP RATING

IP 20 - Protected against the entry of solid bodies larger than 12mm (0.47"); No protection against the entry of liquids.

SAFETY SPECIFICATIONS

Minimum distance of illuminated objects 8 meters
Minimum distance from flammable materials 0.2 meters
Max ambient temperature 40°C (104°F)
Max temperature of the external surface 90°C (194°F)
Automatic break in power supply in case of overheating
Forced ventilation with axial fans

ELECTRONICS

Long life self-charging buffer battery
Function reset from the lighting desk
"AUTOTEST" function from menu
Electronic monitoring with status error
Cooling system monitoring
DMX level monitoring on all channels
Internal data transmission diagnostics

Firmware Upgrade via Web Server

Firmware upload from another fixture

Protocols/Functions: RDM, Web Server

OPTICS

Zoom 3° - 36°, Linear and motorized

EFFECTS SECTION

Six beam reducers (down to 0.5°)
CMY color mixing
15 colors on 3 wheels
2 CTO filters
Rotating Gobo Wheel: 8 interchangeable glass gobos
Static Gobo Wheel: 18 fixed gobos
Rotating 4-facet prism on dedicated channel
Rotating 8-facet prism on dedicated channel
Dynamic Animation disc
Linear soft edge frost filter
Dimmer and stop/strobe
Dense, Sharp, Parallel Light Beams
Extremely quick movements
Excellent visual effect projections
Wide and sharp aerial effects

CONTROL AND PROGRAMMING

DMX 512 control channels
Control signal USITT DMX 512
Protocols RDM, WebServer and Art-Net
Display Graphic LCD backlit b/w Display
Display battery Long life self-charging buffer battery
Pan/Tilt Resolution 16 bit
Focus Resolution 16 bit
Gobo Resolution 16 bit
Dimmer Resolution 16 bit
DMX signal connection 5 pole XLR input and output
Ethernet Input
Firmware update Software upload through Ethernet input

BODY

Aluminum and steel structure with plastic covers
Two side handles for transportation
Device locking PAN and TILT mechanisms for transportation and maintenance

MOVING BODY

PAN range 540°
TILT range 270°

WORKING POSITION

Working in any position
Hanging system: with fast-lock omega clamps (1/4 turn) on the base

CE MARKING

In conformity with the European Directives:

- 2014/35/EU - Safety of electrical equipment supplied at low voltage (LVD)
- 2014/30/EU - Electromagnetic Compatibility (EMC)
- 2011/65/EU - Restriction of the use of certain hazardous substances (RoHS)
- 2009/125/EC - EcoDesign requirements for Energy-related Products (ErP)

WEIGHT

23 Kg

Cause and solution of problems

THE PROJECTOR WILL NOT SWITCH ON			<i>PROBLEMS</i>
ELECTRONICS NON-OPERATIONAL			
DEFECTIVE PROJECTION			
REDUCED LUMINOSITY			
		<i>POSSIBLE CAUSES</i>	<i>CHECKS AND REMEDIES</i>
●		No mains supply.	Check the power supply voltage.
●	●	Lamp exhausted or defective.	Replace the lamp. (See instructions).
	●	Signal transmission cable faulty or disconnected.	Replace the cables.
	●	Incorrect addressing.	Check addresses (see instructions).
	●	Fault in the electronic circuits.	Call an authorised technician.
	●	Lenses or reflector broken	Call an authorised technician.
	● ●	Dust or grease deposited.	Clean (see instructions).

